



# Critical Power Solutions



# Table of Contents

GE Energy Connections.....	4
The GE Store .....	5
GE Beliefs.....	6
GE's Critical Power Overview .....	8
Powering the Rio 2016 Olympic and Paralympic Games .....	8
Industrial Solutions Innovation.....	10
Industrial Solutions .....	12
Setting New Standards in UPS Quality and Innovation .....	13
GE's UPS Firsts (50-Year History) .....	15
UPS Topologies.....	16
High Power UPS.....	18
TLE Series — 3-phase CE, 160 - 200 - 320 - 400 - 600 - 800 kW.....	18
SG Series — 3-phase CE, 10 - 15 - 20 - 30 - 40 - 60 - 80 - 120 - 160 - 200 - 250 - 300 - 400 - 500 kVA .....	20
Mid Power UPS.....	24
TLE Series — 3-phase CE, 40 - 60 - 80 - 100 - 120 kW Scalable .....	24
Low Power UPS.....	26
TLE Series — 3-phase CE, 30 - 40 kW .....	26
TLE Series — 3-phase CE, 30 - 60 - 90 - 120 - 150 - 180 kVA.....	28
LP33 Series — 3-phase CE, 10 - 20 - 30 - 40 kVA.....	30
LP11/31T Series — 1-phase/3-phase in, 1-phase out CE, 3 - 5 - 6 - 8 - 10 kVA.....	32
LP31 Series — 3-phase to 1-phase CE, 8 - 10 - 15 - 20 kVA .....	34
GT Series — 1-phase CE, 6 - 10 kVA.....	36
VH Series — 1-phase CE, 700 - 1000 - 1500 - 2000 - 3000 VA.....	38
VCO Series — 1-phase CE, 1000 - 2000 - 3000 VA.....	40
VCL Series — 1-phase CE, 400 - 600 - 800 - 1000 - 1500 VA .....	42
UPS Key Features/Capabilities.....	44
Ultra-High Efficiency with eBoost™ .....	44
eBoost and Harmonics.....	46
eBoost on TLE Series UPS.....	47
Redundant Parallel Architecture™ (RPA) System Configuration .....	48
Intelligent Emergency Management Integrated (IEMi).....	49
Connectivity Solutions for UPS.....	50
Monitoring & Predictive Analytics.....	52
GE's Battery Monitoring System .....	52
iUPSGuard.....	54
Remote Monitoring Solution for UPS .....	54
GE UPS Watch Distributed Architecture & Licensing Options.....	56
Distributed Architecture & Licensing Options .....	57
Transfer Switches .....	58
STS Series — Static Transfer Switches.....	58
GTX Series — Emergency Standby ATS .....	60
ZTG Series — General Purpose ATS .....	61
ZTS Series — Business Critical and Industrial Applications .....	62
ZTE Series — Mission, Process, Healthcare Critical .....	64
GE UPS Solutions .....	68
Complementary Matching Switchgear — For GE TLE CE UPS, 30-800kVA .....	68
UPS Maintenance Bypass Panel.....	69
DC Energy Storage Flywheel.....	70
UPS Output Power Rating (kVA) .....	71
PowerMOD Modular Container.....	72

# Table of Contents (Cont.)

Factory Services .....	74
Project Management .....	74
Factory Acceptance Testing .....	74
GE UPS Services.....	76
Our Service Portfolio .....	76
On-Site & Emergency Services .....	76
Parts and Repairs.....	76
Contractual Services .....	76
Training.....	76
Maintenance Programs .....	76
Contract Features.....	77
Target Vertical Markets .....	78
Data Centers.....	78
GE Additive .....	80
Rail.....	82
Healthcare.....	84
Maritime.....	86
Misc, Application & Technical Notes.....	90
IS Power Distribution System.....	90
Transformers.....	92
Circuit Breakers & Selectivity .....	96
Battery Technologies.....	98
GE Energy Connections.....	100



# GE Energy Connections

GE **imagines** things others don't. **Builds** things others can't. And **delivers** outcomes that make the world work better.



**Power:**  
Combustion science and services, installed base



**Energy Connections:**  
Electrification and automation technology



**Renewable Energy:**  
Sustainable power systems and storages



**Oil & Gas:**  
Services and technology—a first-mover in growth regions



**Aviation:**  
Advanced materials, manufacturing and engineering productivity



**Transportation:**  
Engine technology and localization in growth regions



**Healthcare:**  
Diagnostics technology—a first-mover and anchor in growth segments



**Home & Business:**  
Providing a gateway to energy efficiency

**GE Digital**

**Global Research Center**

**Culture + Simplification**

**Global Growth Organization**



# The GE Store

Driving competitive advantage across our businesses

Governed by culture and simplification

Supported by GE Capital: Financing infrastructure investments

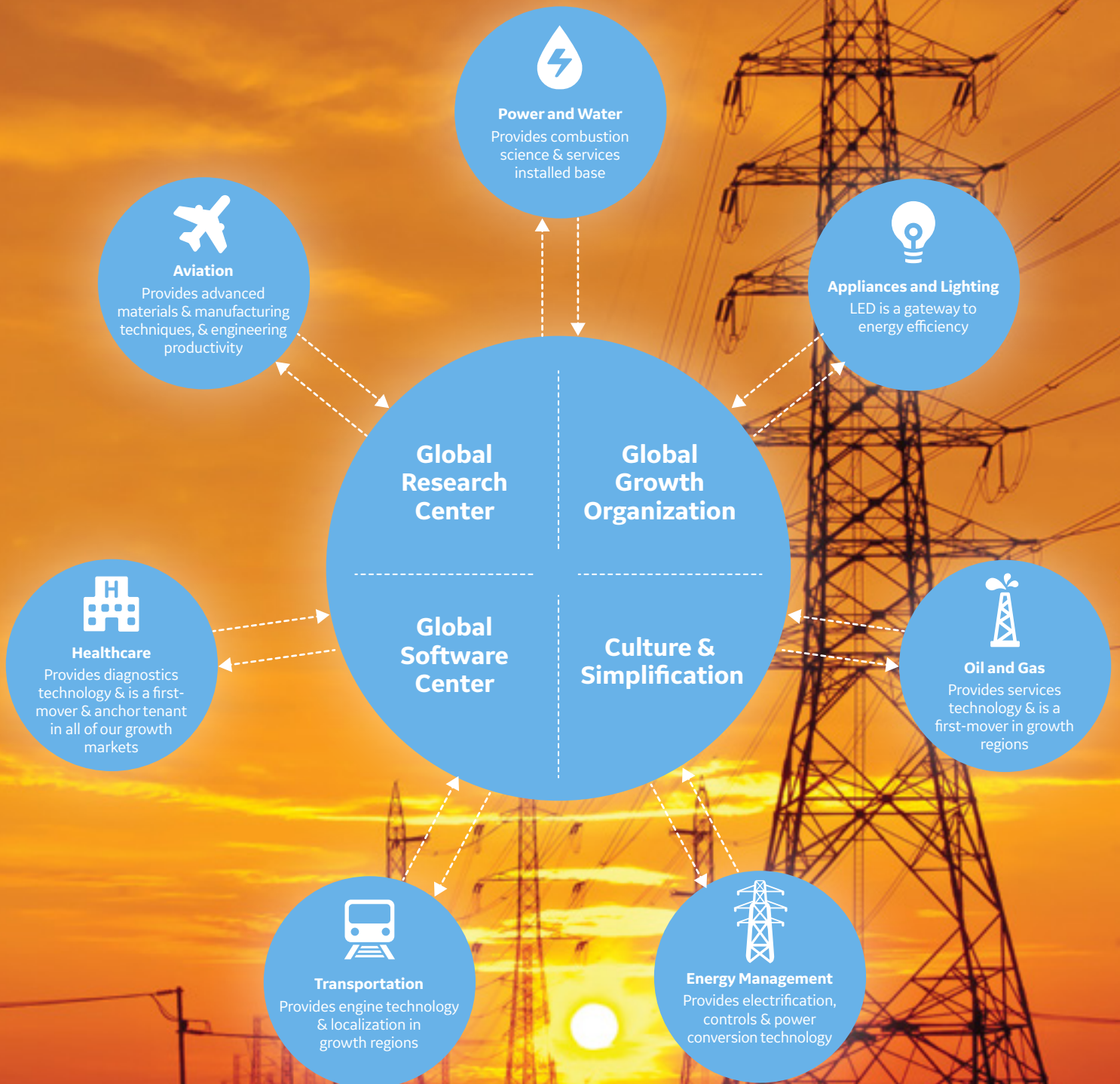

# GE Beliefs

## GE Beliefs offer a new mindset, spirit and behaviors to help us deliver on Simplification.

Customers determine our success and drive us to:

- Stay lean to go fast
- Learn and adapt to win
- Empower and inspire each other
- Deliver results in an uncertain world

## We continue to win by...



### Growing the best leaders in the world

We invest \$1 billion a year in learning and development. Our evolutionary leadership culture makes us the world's #1 company for leaders.



### Learning and sharing across our teams and with our customers

We cross cultures, industries, and expertise to build deeper relationships and deliver 360-degree solutions.



### Inventing the future in the world's best industrial laboratories

We prototype and build parts and products many believed impossible using advanced manufacturing techniques at our seven Global Research Centers.





### Building essential technology in the world's most Brilliant Factories

With our Predix software platform, we bridge the physical and analytical worlds better than any company in the world.



### Changing ahead of a changing world

We think ahead with Ecomagination, and adapt quickly to meet the world's need for safer, reliable, and more affordable energy.



### We make the world healthier

We spot trends three to five years ahead with healthymagination to improve quality, access and affordability of healthcare.



# Powering the Rio 2016 Olympic and Paralympic Games

GE is a Worldwide Partner and exclusive provider of a wide range of innovative products and services that are integral to staging the Rio 2016 Olympic and Paralympic Games. We continue to work closely with host countries, cities and organizing committees to provide infrastructure solutions for Olympic and Paralympic venues including power, lighting, water treatment and transportation.

We will also be supplying local hospitals with diagnostic imaging equipment and healthcare technology solutions like ultrasound, MRI and electronic medical record technologies to help doctors treat athletes.

Here are just a few highlights of how GE is supporting the Games in Rio de Janeiro...

## Power & Water

Opened in February 2014, the Baixada Fluminense Thermal Power Plant in the city of Seropédica uses GE turbines in a combined cycle to generate up to 530 megawatts of power — enough to supply a city of up to 1.7 million people.

## Mobile Water Treatment

To help ensure the water supply for a population that will jump from 500,000 to 2 million people, GE's ultrafiltration membranes will safely treat water.

## Energy Management

GE will supply electrical distribution technologies to the International Broadcast Centre (IBC), which will house the TV and radio





stations and portals from around the world that hold the rights to broadcast the Games. All the energy that fuels the center's operation will pass through this system.

## Healthcare

Focused on the healthcare and well-being of athletes and their teams during the Rio 2016 Olympic and Paralympic Games, GE Healthcare will provide the diagnostic medical equipment, such as MRIs, ultrasounds and digital X-rays, for prevention and diagnosis.

## Lighting

For over three years, GE's team has been taking part in the most important lighting projects related to the Rio 2016 Olympic and Paralympic Games, including the Games' soccer stadiums and the stage for the Rio 2016 Olympic and Paralympic Opening and Closing Ceremony. The technology provides viewers with a clear view of the playing field, both live and on TV.

In addition, GE Lighting has met the lighting needs for the city's infrastructure projects, commercial buildings and hotels. The new technology has made the area more beautiful and safer, while saving 50% in energy consumption compared to the previously used technology.

In fact, using GE's Ecomagination business platform, which aims to meet the challenges in efficient energy and water use, the site has installed 3,000 LED Lumination™ units, which will save about \$ 1 million in energy costs over their four years of operations, compared with fluorescent technology.

## UPS Backup

GE has also supplied and installed 25 Uninterruptible Power Supply (UPS) units to ensure the power supply for ten minutes in the event of an outage, while the generators kick in, preventing any interruptions of work at the headquarters.

Look for more updates as the Rio 2016 Games get closer and visit [HERE](#).



# Industrial Solutions Innovation

## Changing Ahead of a Changing World

Through its Industrial Solutions business, GE is one of the leading manufacturers of electrical distribution equipment in the world. One of our largest electrical distribution equipment manufacturing sites is located in Bielsko-Biala, Poland. Of course, this location was not chosen by chance. Surrounded by beautiful mountains and home to approximately 180,000 people, Bielsko-Biala is one of Poland's most important industrial centers. Often called "Little Vienna", Bielsko-Biala has been known for its industrial activity ever since the city's founding in the 13th century when the textile industry was booming. Today, more than 35 automotive and industrial factories are located in Bielsko-Biala.

In 2014, GE embarked on a project to move four old manufacturing sites consisting of 20 buildings in to a single, new location in Bielsko-Biala. Construction of the new facility started in early January 2015. During



that time 50,000 cubic meters of soil were evacuated from the site, 12,000 cubic meters of concrete were poured and 317 support columns were placed. After eight months, a new factory was erected.

The new facility is approximately 45,000 square meters of space – that’s the size of nearly 11 football pitches. The factory serves customers around the world. Products are manufactured, assembled and shipped to customers in Europe, Latin America, the Middle East, North America and Asia. The Bielsko-Biala factory is designed to help accelerate product development and manufacturing by combining engineering, development, testing and manufacturing operations in a centralized, high-tech environment. The facility is considered a “Brilliant Factory” because of the many advanced manufacturing tools and processes used on the shop floor.



# Industrial Solutions

Built for the **digital industrial era**, our portfolio includes electrical equipment, components and lifecycle services.

## Protection & Distribution

- Busway
- Circuit Breakers
- Enclosures
- Generator Accessories
- Home Automation
- Load Centers
- Modular Metering
- Panelboards
- Power Equipment Buildings
- Power Pedestals
- Switchboards
- Switches & Disconnects
- Switchgear
- Transformers
- Trip Units

## Motor & Lighting Control

- Contactors
- Drives
- Lighting Control
- Motor Control Centers
- Push Buttons & Pilot Devices
- Relays & Timers
- Starters
- Terminal Blocks

## Lifecycle Services

- Power System Study
- Arc Flash Study
- Emergency & Rapid Response
- On-going Maintenance Services
- Inspection Services
- Training

## Critical Power

- Automatic Transfer Switches
- Critical Power Distribution
- Data Center Solutions
- DC Power Systems
- Embedded Power
- Static Transfer Switches
- Surge Protective Devices
- Uninterruptible Power Supplies (UPS)

## Our Global Footprint

Worldwide Scale with Local Execution

Our 14,000 employees deliver solutions in more than 100 countries.

## Our Global Footprint



**Manufacturing  
Facilities**

**29**



**Distribution  
Centers**

**15**



**Testing  
Centers / Labs**

**9**



**Service  
Centers**

**13**



# Setting New Standards in UPS Quality and Innovation

In 1966, GE provided the first commercial UPS solution—and we've been innovating ever since. Today, you can rely on GE's Critical Power to deliver the powerful, dependable UPS solutions you need with advanced features and benefits unrivaled in the industry. Here are just a few of the latest innovations...

## Energy Efficiency

We offer the most energy efficient double-conversion UPS in the industry, providing world-class energy efficiency across the operating load range. The TLE Series, for example, delivers efficiency up to 96.5% in double conversion mode and 99% in eBoost operating mode. This system efficiency substantially reduces operating and cooling costs thus providing a reduced cost of ownership and improved power usage effectiveness (PUE) compared to conventional UPS.

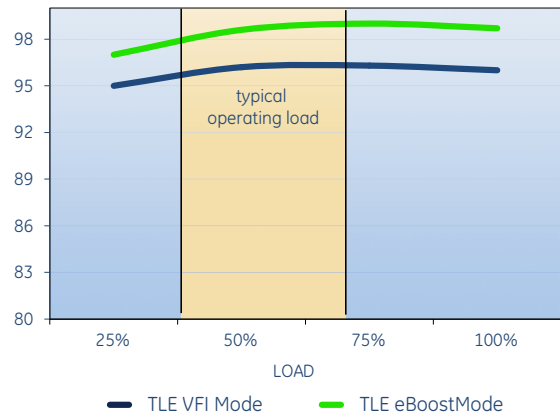

## Diagnostic Capability

New diagnostic features allow you to store different wave forms while also providing fan failure detection as well as warning on capacitor life that improves UPS availability and enhances preventive maintenance capabilities.

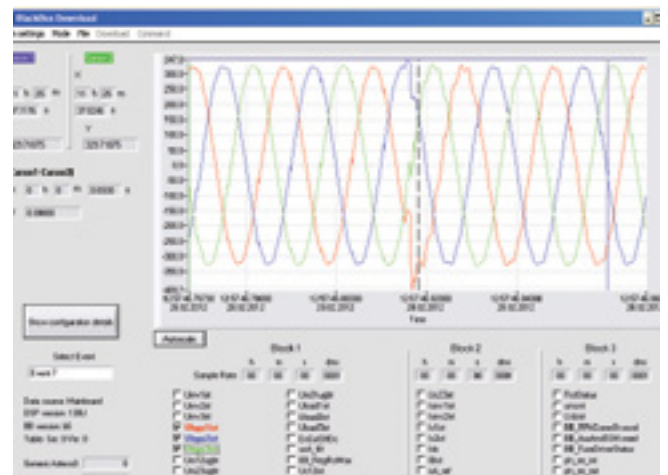

## Standard Safety and Maintenance Features

Our high-power UPS such as the TLE Series, has standard built in back-feed protection as well maintenance switch that avoids external in-stallation of switches or breakers into input distribution panels for providing back feed protection and maintenance disconnect.



Thomas Edison, founder

# GE's UPS Firsts

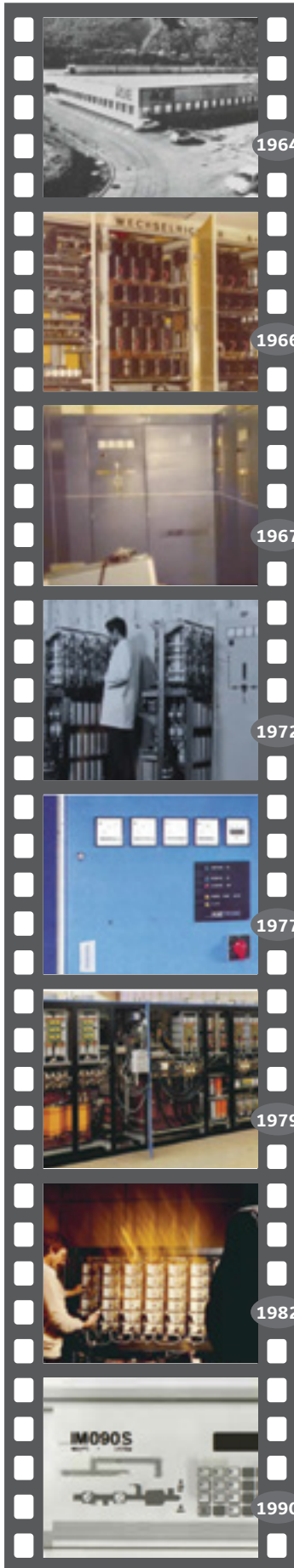

**1964** > Development of the first UPS - AGIE in Losone

**1966** > The first commercial UPS-systems were supplied: Two single UPS of 36kVA - 60Hz and 20kVA - 50Hz

**1967** > First parallel system, 5 units 125kVA with bypass centralized and redundant control; Innovative technology for paralleling UPS in European market

**1972** > First redundant parallel UPS-system: 6x250kVA model 035

**1977** > First UPS with transistor type 050, using the revolutionary technology PWM

**1979** > First UPS of type 060 of 250kVA

**1982** > First UPS model IM085 250kVA

**1986** > First UPS model IM075 120kVA; This model was controlled by an 8-bit microprocessor

**1987** > First system in parallel from 3x250kVA (up to 6 units) type IM095 with the new decentralized bypass

**1990** > First UPS model IM090 120kVA with bipolar transistors

**1992** > First IM090 330kVA with transistors IGBT

**1993** > First IM090 from 500kVA with transistors IGBT

**1996** > Launch of the UPS platform SitePro, ranging from 10 to 500kVA

**2000** > Launch of the transformer-less UPS LanPro 33, ranging from 10 to 30kVA

**2003** > First SG Series UPS ranging from 80 to 200kVA

**2007** > Launched new PurePulse technology (IGBT rectifier) for the SG Series available from 60 to 500kVA; Development of high performances single-phase UPS VH Series from 0.7 to 3kVA

**2008** > Launched SG Series UL 750kVA for large data center applications in US

**2010** > Launched SG Series 600kVA for large datacenter in Europe

**2011** > Launch of iUPSGuard to provide remote monitoring of all UPS product lines— anytime, anywhere, from any device

**2013** > Launch TLE High Efficiency 3 Level Technology

**2014** > GE develops the 1st Ring Bus architecture with Static UPS to optimize performance, reliability and cost

**2016** > Introduced TLE low-to-mid power modern UPS with unrivalled quality, scalability and extended product life

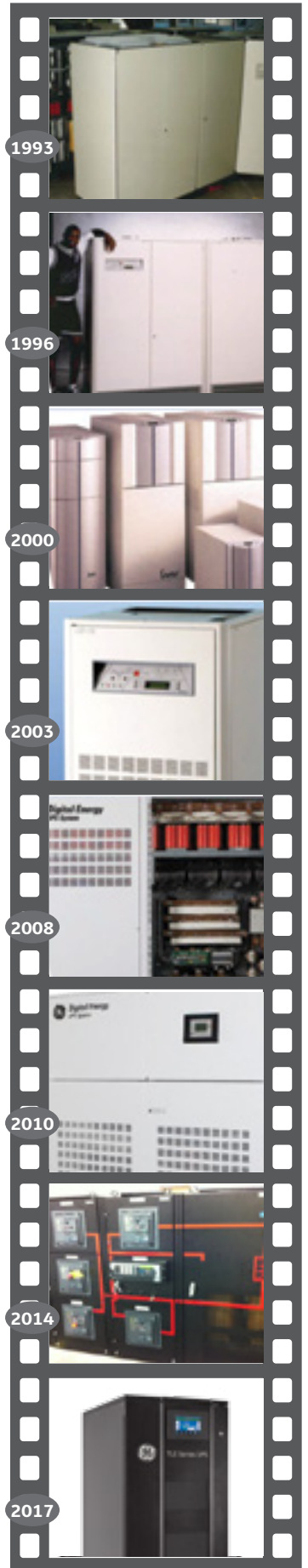

**2017** > Introduced the TLE Series 30-180 kVA Scalable with optimized front access for easy installation and service access.

# UPS Topologies

## Offline - VFD (Voltage Frequency Dependent)

Offline UPS system channels the incoming mains power, via a filter, directly to the load. As soon as the incoming power is outside tolerance, the UPS switches to battery operation.

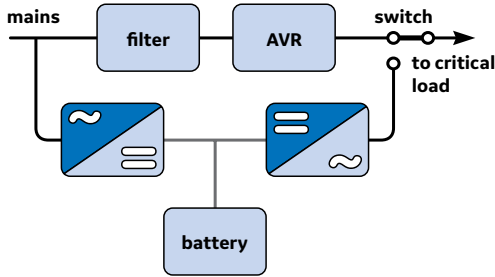
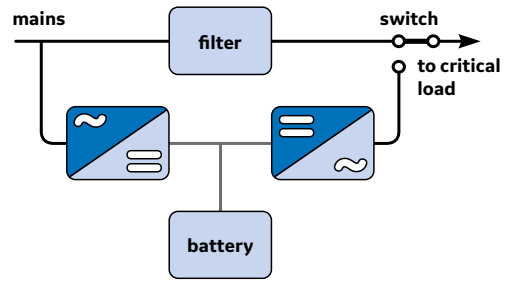

## Line-interactive - VI (Voltage Independent)

Line-interactive UPS system channels the incoming mains power, via an AVR - Automatic Voltage Regulator, directly to the load. Compared to off-line, the system can handle much larger voltage variations before switching to battery operation.

## Double-conversion - VFI (Voltage Frequency Independent)

Input and output are completely separated: the output converter (DC to AC, or = to ~) continuously supplies the critical load with a completely new, regulated and clean sine wave output. No switching takes place when the incoming mains power gets outside tolerances. A bypass switch automatically transfers the load to the mains when the output converter is unable to supply the load.

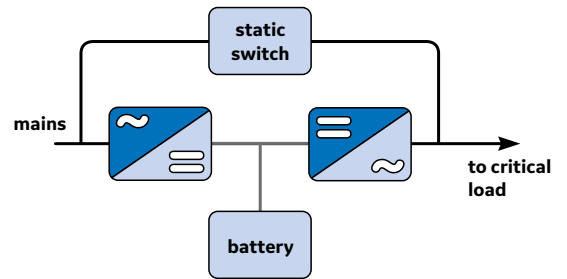

MAINS DISTURBANCES		VFD	VI	VFI
Power failure (black-out)		✓	✓	✓
Power sags			✓	✓
Power surge			✓	✓
Under-voltage			✓	✓
Over-voltage			✓	✓
Transient				✓
Voltage noise				✓
Voltage harmonics				✓
Frequency variations				✓





# High Power UPS

## TLE Series - VFI Double-Conversion Transformerless UPS

3-phase CE, 160 - 200 - 320 - 400 - 600 - 800 kW



### Overview

The TLE Series provides the latest power conversion technology in a transformerless UPS, using rectifiers and inverters with a three-level IGBT design for high double conversion VFD efficiency and even higher efficiency in multi-mode operation (eBoost) that makes real-time decisions between VFI double conversion and VFD eco mode. The TLE Series UPS was developed using GE's Design for Six Sigma (DFSS) methodology to ensure this transformerless UPS product meets customer requirements for critical power performance, reliability, efficiency and quality.

### Features and Benefits

- Highly reliable and efficient three-level IGBT power conversion
- Multi-mode high efficiency operation (eBoost)
  - Up to 97% Efficient in VFI double conversion mode
  - Up to 99% Efficient in VFD eco mode
- Unity (1.0) Output Power Factor
- High (0.99) Input Power Factor
- Less than 5% Input Current Harmonic Distortion
- Small footprint and high power density
- Front access design for ease of maintenance reducing mean time to repair (MTTR)

### Function

Providing reliable and efficient power protection for IT servers/storage/network equipment and other digital electronics

### Typical Applications

- Data centers – cloud, colocation and enterprise
- Telecommunication installations
- Internet service providers
- Security operations
- Process control equipment
- Financial systems
- Healthcare

### Options

- Redundant Parallel Architecture (RPA) for paralleling up to six (6) TLE modules for redundancy and high reliability
- RPA “cable saver” allow wider cable length differences between UPS modules when paralleling multiple modules
- Matching VRLA battery cabinets with wide range of battery runtimes
- Flywheel energy storage
- External maintenance bypass cabinets
- Connectivity options (SNMP, customer interface cards, remote status panels, iUPSGuard remote monitoring)



### Standards & Certification

Safety: EN 62040 (EN 62050-1)

EMC: EN 62040-2

# Specifications

GENERAL DATA	TLE SERIES 160 CE	TLE SERIES 200 CE	TLE SERIES 320 CE	TLE SERIES 400 CE	TLE SERIES 600 CE	TLE SERIES 800 CE
<b>Topology</b>	VFI, double conversion					
<b>Nominal output power</b>	160kW	200kW	320kW	400kW	600kW	800kW
<b>Overall efficiency in VFI mode</b>	96.6%					
<b>Overall efficiency in eBoost mode</b>	98.9%					
<b>Audible noise level</b>	74dB(A)				74dB(A) / 68dB(A)	
<b>Operating temperature range</b>	UPS: 0°C - 40°C (up to 50°C subjected to conditions)					
<b>Protection degree</b>	IP 20 (IEC 60529)					
<b>Standards</b>	EN/IEC 62040, CE marking					
<b>EMC (Electromagnetic Compatibility)</b>	EN/IEC 62040-2					
<b>Electrostatic discharge immunity</b>	4kV contact / 8kV air discharge					
<b>Colour</b>	RAL 9005 (black)					
<b>Service access</b>	Front and top access only					
<b>External cable connections</b>	Bottom of the cabinet (Top as option)					
<b>Paralleling (RPA version)</b>	Up to 6 units for redundancy or capacity in RPA configuration (option)					

RECTIFIER	
<b>Standard input voltage</b>	Nominal: 3x400V + N Programmable: 3x380 / 415V + N Rectifier accepted ph-ph voltage range: 340V - 460V
<b>Input frequency</b>	50/60 Hz +/-10% (45 - 66 Hz)
<b>Power factor</b>	0.99
<b>Input current THD</b>	<3%

BATTERY	
<b>Battery type</b>	Valve regulated lead-acid (VRLA)-standard, Vented lead-acid, wet battery and NiCd
<b>Float voltage at 20°C</b>	545V - 600V (dependent on the number of cells)
<b>Common battery in parallel system</b>	Up to 3 units

INVERTER	
<b>Nominal output voltage (on site programmable)</b>	3x380V / 400V / 415V + N
<b>Output frequency</b>	50/60 Hz (selectable)
<b>Output voltage tolerance: static</b>	+/- 1%
<b>Output voltage tolerance: dynamic (at load step 0 - 100 - 0%)</b>	+/- 3%
<b>- output voltage THD for 100% linear load</b>	<3%
<b>- output voltage THD for 100% non-linear load (EN 62040)</b>	<5%
<b>Output frequency tolerance: free-running</b>	+/- 0.1%
<b>Overload capability (at 25°C ambient temperature)</b>	105% continuous, 110% - 10 minutes, 125% - 1 minute, 150% - 30 seconds

BYPASS	
<b>Voltage limits for inverter/ bypass load transfers</b>	+/- 10% (adjustable)
<b>Overload on bypass</b>	150% for 1 minute & 22 times In for 10ms, non repetitive – 110% continuous
<b>Primary components</b>	Static switch (SCR) on bypass Electromechanic contactor (backfeed protection) on bypass and inverter 2 manual switches for maintenance bypass

INTERFACING	
<b>RS232 serial port, EPO, Customer Interface board</b>	Standard

PHYSICAL DATA				
<b>Weight</b>	500 Kg	980 Kg	2200 Kg	2380 Kg
<b>Floor loading</b>	705 Kg/m2	798 Kg/m2	848 Kg/m2	805 Kg/m2
<b>Dimensions (WxDxH)</b>	820x865x1905 mm	1420x865x1905 mm	3000x865x1905 mm	3420x865x1905 mm

# SG Series - VFI Double-Conversion Transformer UPS

3-phase CE, 10 - 15 - 20 - 30 - 40 - 60 - 80 - 120 - 160 - 200 - 250 - 300 - 400 - 500 kVA



## Overview

The SG Series is one of the most efficient, robust and reliable transformer UPS, providing best-in-class input and output power quality performance and protection for wide range of critical power applications. The SG Series is designed with IGBT rectifier (PurePulse) for clean input performance and output inverter with zig zag transformer for best-in-class harmonics, voltage regulation and dynamic response. The SG is also optimized to provide high efficiency at part load conditions.

## Features and Benefits

- PurePulse IGBT rectifier for clean input power quality with high input PF and low harmonics distortion
- Inverter output zig-zag isolation transformer for short circuit capability and load galvanic separation
- Enhanced output performance with lagging-leading power factor (0.9) without kVA derating
- Excellent dynamic output performance and low output voltage distortion
- High efficiency in double conversion up to 94% and in eBoost mode operation up to 99%
- Front access for operation and maintenance reducing mean time to repair (MTTR)

## Function

Providing reliability power protection for challenging critical loads with step loads, high harmonics and poor power quality

## Typical Applications

- Data centers – corporate and enterprise
- Transportation and Rail
- Telecommunication installations
- Manufacturing & Process control
- Financial & banking systems
- Healthcare & Hospitals
- Broadcast



## Options

- Redundant Parallel Architecture (RPA) for paralleling up to six (6) SG modules for redundancy and high reliability
- Matching VRLA battery cabinets with wide range of battery runtimes
- Flywheel energy storage
- External maintenance bypass cabinets
- Connectivity options (SNMP, customer interface cards, remote status panels, iUPSGuard remote monitoring)

## Standards & Certification

Safety: EN 62040 (EN 62050-1)

EMC: EN 62040-2

## Specifications

GENERAL DATA	SG SERIES 10 PUREPULSE CE S1	SG SERIES 15 PUREPULSE CE S1	SG SERIES 20 PUREPULSE CE S1	SG SERIES 30 PUREPULSE CE S1	SG SERIES 40 PUREPULSE CE S1
Topology	VFI, double conversion				
Nominal output power	10kW	15kW	20kW	30kW	40kW
Overall efficiency in VFI mode	Up to 92.3%				
Overall efficiency in eBoost mode	Up to 98.0%				
Audible noise level	58dB(A)				
Operating temperature range	0 °C - 40 °C				
Protection degree	IP 20 (IEC 60529)				
Standards	EN/IEC 62040, CE marking				
EMC (Electromagnetic Compatibility)	EN/IEC 62040-2				
Electrostatic discharge immunity	4kV contact / 8kV air discharge				
Colour	RAL 9003 (white)				
Service access	Front and top access only				
External cable connections	Bottom at front of the cabinet (standard)				
Paralleling (RPA version)	Up to 6 units for redundancy or capacity in RPA configuration (option)				

RECTIFIER	
Standard input voltage	Nominal: 3x400V + N Programmable: 3x380 / 415V + N Rectifier accepted ph-ph voltage range: 340V - 460V
Input frequency	50/60 Hz +/-10% (45 - 66 Hz)
Power factor	0.99
Input current THD	2% at 100% load <2.5% at 75% load <3% at 50% load

BATTERY	
Battery type	Valve regulated lead-acid (VRLA)-standard, Vented lead-acid, wet battery and NiCd, Flywheel compatible
Float voltage at 20°C	400V - 436V (dependent on the number of blocks)

INVERTER	
Nominal output voltage (on site programmable)	3x380V / 400V / 415V + N
Output frequency	50/60 Hz (selectable)
Output voltage tolerance: static	+/- 1%
Output voltage tolerance: dynamic (at load step 0 - 100 - 0%)	+/- 3%
- output voltage THD for 100% linear load	< 2%
- output voltage THD for 100% non-linear load (EN 62040)	3%
Output frequency tolerance: free-running	+/- 0.1%
Overload capability (at 25°C ambient temperature)	125% - 10 minutes, 150% - 1 minute

BYPASS	
Voltage limits for inverter/ bypass load transfers	+/- 10% (adjustable)
Overload on bypass	200% for 1 minute & 35 times In for 10 ms, non repetitive
Primary components	Static switch (SCR) on bypass Electromechanic contactor (backfeed protection) Manual switch for maintenance bypass

INTERFACING	
RS232 serial port, EPO, Customer Interface board	Standard

PHYSICAL DATA			
Weight	290 Kg	350 Kg	420 Kg
Floor loading	533 Kg/m2	643 Kg/m2	772 Kg/m2
Dimensions (WxDxH)	680x800x1450mm		

## Specifications

GENERAL DATA	SG SERIES 60 PUREPULSE CE S1	SG SERIES 80 PUREPULSE CE S1	SG SERIES 100 PUREPULSE CE S1	SG SERIES 120 PUREPULSE CE S1
Topology	VFI, double conversion			
Nominal output power	60kVA/54kW	80kVA/72kW	100kVA/90kW	120kVA/108kW
Overall efficiency in VFI mode	92.1%			
Overall efficiency in eBoost mode	97.9%			
Audible noise level	63dB(A)			
Operating temperature range	0 °C - 40 °C			
Protection degree	IP 20 (IEC 60529)			
Standards	EN/IEC 62040, CE marking			
EMC (Electromagnetic Compatibility)	EN/IEC 62040-2			
Electrostatic discharge immunity	4kV contact / 8kV air discharge			
Colour	RAL 9003 (white), bottom air grids RAL 7021 (black)			
Service access	Front and top access only			
External cable connections	Bottom at front of the cabinet (top as option)			
Paralleling (RPA version)	Up to 6 units for redundancy or capacity in RPA configuration (option)			

RECTIFIER	
Standard input voltage	Nominal: 3x400V + N Programmable: 3x380 / 415V + N Rectifier accepted ph-ph voltage range: 340V - 460V
Input frequency	50/60 Hz +/-10% (45 - 66 Hz)
Power factor	0.99
Input current THD	2% at 100% load <2.5% at 75% load <3% at 50% load

BATTERY	
Battery type	Valve regulated lead-acid (VRLA)-standard, Vented lead-acid, wet battery and NiCd
Float voltage at 20°C	400V - 436V (dependent on the number of blocks)

INVERTER	
Nominal output voltage (on site programmable)	3x380V / 400V / 415V + N
Output frequency	50/60 Hz (selectable)
Output voltage tolerance: static	+/- 1%
Output voltage tolerance: dynamic (at load step 0 - 100 - 0%)	+/- 3%
- output voltage THD for 100% linear load	Max. 1.5%
- output voltage THD for 100% non-linear load (EN 62040)	Max. 3%
Output frequency tolerance: free-running	+/- 0.1%
Overload capability (at 25°C ambient temperature)	125% - 10 minutes, 150% - 1 minute

BYPASS	
Voltage limits for inverter/ bypass load transfers	+/- 10% (adjustable)
Overload on bypass	200% for 5 minutes & 45 times In for 10 ms, non repetitive
Primary components	Static switch (SCR) on bypass Electromechanic contactors (backfeed protection) 2 Manual switches for maintenance bypass and inverter

INTERFACING	
RS232 serial port, EPO, Customer Interface board	Standard

PHYSICAL DATA			
Weight	550 Kg	630 Kg	860 Kg
Floor loading	995 Kg/m <sup>2</sup>	1140 Kg/m <sup>2</sup>	1212 Kg/m <sup>2</sup>
Dimensions (WxDxH)	650x850x1900 mm		835x850x1900 mm

# Specifications

GENERAL DATA	SG SERIES 160 PUREPULSE CE S3	SG SERIES 200 PUREPULSE CE S3	SG SERIES 250 PUREPULSE CE S3	SG SERIES 300 PUREPULSE CE S3	SG SERIES 400 PUREPULSE CE S3	SG SERIES 500 PUREPULSE CE S3
Topology	VFI, double conversion					
Nominal output power	160kVA/144kW	200kVA/180kW	250kVA/225kW	300kVA/270kW	400kVA/360kW	500kVA/450kW
Overall efficiency in VFI mode	94.6%					
Overall efficiency in eBoost mode	98.7%					
Audible noise level	69dB(A)				72dB(A)	
Operating temperature range	0 °C - 40 °C					
Protection degree	IP 20 (IEC 60529)					
Standards	EN/IEC 62040, CE marking					
EMC (Electromagnetic Compatibility)	EN/IEC 62040-2					
Electrostatic discharge immunity	4kV contact / 8kV air discharge					
Colour	RAL 9005 (black)					
Service access	Front and top access only					
External cable connections	Bottom at front of the cabinet (top as option)					
Paralleling (RPA version)	Up to 6 units for redundancy or capacity in RPA configuration (option)					

RECTIFIER	
Standard input voltage	Nominal: 3x400V + N Programmable: 3x380 / 415V + N Rectifier accepted ph-ph voltage range: 340V - 460V
Input frequency	50/60 Hz +/-10% (45 - 66 Hz)
Power factor	0.99
Input current THD	2% at 100% load <2.5% at 75% load <3% at 50% load

BATTERY	
Battery type	Valve regulated lead-acid (VRLA)-standard, Vented lead-acid, wet battery and NiCd, Flywheel compatible
Float voltage at 20°C	400V - 436V (dependent on the number of blocks)

INVERTER	
Nominal output voltage (on site programmable)	3x380V / 400V / 415V + N
Output frequency	50/60 Hz (selectable)
Output voltage tolerance: static	+/- 1%
Output voltage tolerance: dynamic (at load step 0 - 100 - 0%)	+/- 3%
- output voltage THD for 100% linear load	Max. 1.5%
- output voltage THD for 100% non-linear load (EN 62040)	Max. 3%
Output frequency tolerance: free-running	+/- 0.1%
Overload capability (at 25°C ambient temperature)	125% - 10 minutes, 150% - 1 minute

BYPASS	
Voltage limits for inverter/ bypass load transfers	+/- 10% (adjustable)
Overload on bypass	150% for 1 minute & 45 times In for 10 ms, non repetitive
Primary components	Static switch (SCR) on bypass Electromechanic contactors (backfeed protection) on bypass and inverter 2 Manual switches for maintenance bypass

INTERFACING	
RS232 serial port, EPO, Customer Interface board	Standard

PHYSICAL DATA						
Weight	1050 Kg	1220 Kg	1470 Kg	1560 Kg	2190 Kg	2470 Kg
Floor loading	1373 Kg/m2	1105 Kg/m2	1331 Kg/m2	1412 Kg/m2	1281 Kg/m2	1445 Kg/m2
Dimensions (WxDxH) mm	900x850x1900	1300x850x1900	1300x850x1900	1300x850x1900	1800x950x1900	1800x950x1900

# Mid Power UPS

## TLE Series - VFI Double-Conversion Transformerless UPS

3-phase CE, 40 - 60 - 80 - 100 - 120 kW Scalable



### Function

Easy to install, service and grow, the TLE40-120 Scalable is optimized for office environments, but also suitable for more traditional, industrial applications.

### Typical Applications

- IT Rooms
- Transportation and Rail
- Telecommunication installations
- Manufacturing & Process control
- Financial & banking systems
- Healthcare & Hospitals
- Broadcast



### Standards & Certification

Safety: EN 62040 (EN 62050-1)  
EMC: EN 62040-2

### Overview

The TLE Series UPS is one of the best performing three-phase UPS systems providing critical power protection for a wide range of applications. The TLE Series operates in VFI mode (Voltage Frequency Independent) and has been developed to satisfy the growing request of high efficiency through an innovative control algorithm with 3-level inverter technology. This innovative product provides double conversion operating mode.

The TLE Series UPS provides industry-leading reliability, efficiency, clean input performance and unity power factor at output. Reliability can be further increased by paralleling more units utilizing GE's unique RPA™ (Redundant Parallel Architecture) technology.

### Features and Benefits

- Scalable from 40 to 120kW
- True front access for operation and maintenance reduces mean time to repair (MTTR)
- Standard built in back feed protection and maintenance switch minimize installation cost and increase safety
- Smaller size reduced installation and operational footprint
- Redundant Parallel Architecture (RPA) for reliability, redundancy and scalability up to 6 UPS
- Enhanced output performance with unit power factor to protect and supply modern IT load
- Excellent dynamic performance and low output voltage distortion
- Improved diagnostic capabilities with waveform capture and capacitor monitoring
- Clean input performance with 0.99 input power factor and <3% THDi
- Double conversion efficiency up to 95.4%
- Output power factor 1
- True front access design
- Compact foot print
- Improved user interface
- Extremely low output voltage distortion
- Superior Battery Management

### Options

- Redundant Parallel Architecture (RPA) for paralleling up to six (6) TLE modules for redundancy and high reliability
- RPA "cable saver" allow wider cable length differences between UPS modules when paralleling multiple modules
- Matching VRLA battery cabinets with wide range of battery runtimes
- External maintenance bypass cabinets
- Connectivity options (SNMP, customer interface cards, remote status panels, iUPSGuard remote monitoring)
- Additional power block or license upgrades for more power



# Specifications

GENERAL DATA	TLE SERIES 40 CE S1	TLE SERIES 60 CE S1	TLE SERIES 80 CE S1	TLE SERIES 100 CE S1	TLE SERIES 120 CE S1
Topology	VFI, double conversion				
Nominal output power	40kW	60kW	80kW	100kW	120kW
Overall efficiency in VFI mode	95.4%				
Overall efficiency in SEM	98.9%				
Audible noise level	62dB(A)				
Operating temperature range	0 °C - 40 °C (up to 50 °C subjected to conditions)				
Protection degree	IP 30 (IEC 60529)				
Standards	EN/IEC 62040, CE marking				
EMC (Electromagnetic Compatibility)	EN/IEC 62040-2 Category C3 (Category C2 as option)				
Electrostatic discharge immunity	4kV contact / 8kV air discharge				
Colour	RAL 9005 (black)				
Service access	Front and top access only				
External cable connections	Bottom at front of the cabinet (standard)				
Paralleling (RPA version)	Up to 6 units for redundancy or capacity in RPA configuration (option)				

RECTIFIER	
Standard input voltage	Nominal: 3x400V + N Programmable: 3x380 / 415V + N Rectifier accepted ph-ph voltage range: 340V - 460V (wider voltages subject to de-rated loads)
Input frequency	50/60 Hz +/-10% (45 - 66 Hz)
Power factor	0.99
Input current THD	<3%

BATTERY	
Battery type	Valve regulated lead-acid (VRLA)-standard, vented lead-acid, wet battery and NiCd
Float voltage at 20°C	409V - 490V (dependent on the number of cells)

INVERTER	
Nominal output voltage (on site programmable)	3x380V / 400V / 415V + N
Output frequency	50/60 Hz (selectable)
Output voltage tolerance: static	+/- 1%
Output voltage tolerance: dynamic (at load step 0 - 100 - 0%)	+/- 3%
- output voltage THD for 100% linear load	< 3%
- output voltage THD for 100% non-linear load (EN 62040)	<5%
Output frequency tolerance: free-running	+/- 0.1%
Overload capability (at 25°C ambient temperature)	105% continuous, 110% - 10 minutes, 125% - 1 minute, 150% - 30 seconds

BYPASS	
Voltage limits for inverter/ bypass load transfers	+/- 10% (adjustable)
Overload on bypass	190A continuous - 260A for 1 minute & 3810A for 10ms, non repetitive
Primary components	Static switch (SCR) on bypass Electromechanic contactors (backfeed protection) on bypass and inverter 2 manual switches for maintenance bypass

INTERFACING	
RS232 serial port, EPO, Customer Interface board	Standard

PHYSICAL DATA			
Weight	385 Kg	450 Kg	520 Kg
Floor loading	755 Kg/m2	883 Kg/m2	1020 Kg/m2
Dimensions (WxDxH)	600x865x1630 mm		

# Low Power UPS

## TLE Series - VFI Double-Conversion Transformerless UPS

3-phase CE, 30 - 40 kW



### Function

Easy to install and service, the TLE30-40 is optimized for office environments, but also suitable for more traditional, industrial applications.

### Typical Applications

- IT Rooms
- Transportation and Rail
- Telecommunication installations
- Manufacturing & Process control
- Financial & banking systems
- Healthcare & Hospitals
- Broadcast



### Standards & Certification

Safety: EN 62040 (EN 62050-1)

EMC: EN 62040-2

### Overview

The TLE Series UPS is one of the best performing three-phase UPS systems providing critical power protection for a wide range of applications. The TLE Series operates in VFI mode (Voltage Frequency Independent) and has been developed to satisfy the growing request of high efficiency through an innovative control algorithm with 3-level inverter technology. This innovative product provides double conversion operating mode.

The TLE Series UPS provides industry-leading reliability, efficiency, clean input performance and unity power factor at output. Reliability can be further increased by paralleling more units utilizing GE's unique RPA™ (Redundant Parallel Architecture) technology.

### Features and Benefits

- True front access for operation and maintenance reduces mean time to repair (MTTR)
- Standard built in back feed protection and maintenance switch minimize installation cost and increase safety
- Smaller size reduced installation and operational footprint
- Redundant Parallel Architecture (RPA) for reliability, redundancy and scalability up to 6 UPS
- Enhanced output performance with unit power factor to protect and supply modern IT load
- Excellent dynamic performance and low output voltage distortion
- Improved diagnostic capabilities with waveform capture and capacitor monitoring
- Clean input performance with 0.99 input power factor and <3% THDi
- Double conversion efficiency up to 95.4%
- Output power factor 1
- True front access design
- Compact foot print
- Improved user interface
- Extremely low output voltage distortion
- Superior Battery Management

### Options

- Redundant Parallel Architecture (RPA) for paralleling up to six (6) TLE modules for redundancy and high reliability
- RPA "cable saver" allow wider cable length differences between UPS modules when paralleling multiple modules
- Matching VRLA battery cabinets with wide range of battery runtimes
- External maintenance bypass cabinets
- Connectivity options (SNMP, customer interface cards, remote status panels, iUPSGuard remote monitoring)
- Additional Internal Transformers
- Front Bottom Cable Connection

# Specifications

GENERAL DATA	TLE SERIES 30 CE S1	TLE SERIES 40 CE S1
Topology	VFI, double conversion	
Nominal output power	30kW	40kW
Overall efficiency in VFI mode	95.3%	
Overall efficiency in eBoost mode	98.6%	
Audible noise level	60dB(A)	
Operating temperature range	0 °C - 40 °C (up to 50 °C subjected to conditions)	
Protection degree	IP 20 (IEC 60529 - IP 30 on request)	
Standards	EN/IEC 62040, CE marking	
EMC (Electromagnetic Compatibility)	EN/IEC 62040-2	
Electrostatic discharge immunity	4kV contact / 8kV air discharge	
Colour	RAL 9005 (Black)	
Service access	Front and top access only (castors available on the bottom of the UPS)	
External cable connections	Bottom at the rear of the cabinet. Front connection as option	
Paralleling (RPA version)	Up to 6 units for redundancy or capacity in RPA configuration (option)	

RECTIFIER	
Standard input voltage	Nominal: 3x400V + N Programmable: 3x380 / 415V + N Rectifier accepted ph-ph voltage range: 340V - 460V (lower voltages acceptable with de-rated loads)
Input frequency	50/60 Hz +/-10% (45 - 66 Hz)
Power factor	0.99
Input current THD	<3% at 100% load <5% at 50% load

BATTERY	
Battery type	Valve regulated lead-acid (VRLA)-standard, Vented lead-acid, wet battery and NiCd
Float voltage at 20°C	409V - 490V (dependent on the number of blocks)
GE Batteries Solutions	10 years design life VRLA batteries

INVERTER	
Nominal output voltage (on site programmable)	3x380V / 400V / 415V + N
Output frequency	50/60 Hz (selectable)
Output voltage tolerance: static	+/- 1%
Output voltage tolerance: dynamic (at load step 0 - 100 - 0%)	+/- 3%
- output voltage THD for 100% linear load	<2%
- output voltage THD for 100% non-linear load (EN 62040)	<5%
Output frequency tolerance: free-running	+/- 0.1%
Overload capability (at 25°C ambient temperature)	105% continuous, 110% - 10 minutes, 125% - 1 minute, 150% - 30 seconds

BYPASS	
Voltage limits for inverter/ bypass load transfers	+/- 10% (adjustable)
Overload on bypass	150% for 1 minute & 45 times In for 10 ms, non repetitive
Primary components	Static switch (SCR) on bypass Electromechanic contactors (backfeed protection) on bypass and inverter 2 manual switches for maintenance bypass

INTERFACING	
RS232 serial port, EPO, Customer Interface board	Standard

PHYSICAL DATA	
Weight	230 Kg
Floor loading	542 Kg/m <sup>2</sup>
Dimensions (WxDxH)	500x850x1705 mm

# TLE Modular Series

3-phase CE, 30 - 60 - 90 - 120 - 150 - 180 kVA



## Overview

GE's TLE Modular Series UPS is one of the most reliable three-phase UPS modular systems, designed for N+X redundancy, on-line and hot-swappable. The TLE Modular Series provides compact footprint with high power capability, achieving up to 540kVA in order to guarantee maximum flexibility of system design for any kind of application.

The TLE Modular Series UPS provides high efficiency in all operating conditions keeping high level of protection to critical loads connected, minimizing input current distortion and consequently reducing operational costs. This makes TLE Modular Series UPS a perfect choice for environmental-friendly solutions.

## Function

Easy to install and service, the TLE 30-180 kVA is optimized for office environments, but also suitable for more traditional, industrial applications.

## Typical Applications

- IT Rooms
- Transportation and Rail
- Telecommunication installations
- Manufacturing & Process control
- Financial & banking systems
- Healthcare & Hospitals
- Broadcast



## Features and Benefits

- 30-180kVA modular design
- High power capability up to 540kVA
- On-line efficiency up to 95.5% and 99% in ECO mode
- Clean input performance with >0.99 PF and <3% THDi
- 228-478V accepted input voltage minimizes battery operations
- Low Output Voltage distortion <1% THDU
- User Friendly 10.4" Touch LCD display
- SNMP card included
- Backfeed protection included
- Maintenance Bypass included

## Standards & Certification

Safety: EN 62040 (EN 62050-1)

EMC: EN 62040-2

# Specifications

GENERAL DATA	TLE MODULAR SERIES 30 -180 (1 TO 6 MODULES) kVA
Topology	VFI, double conversion
Nominal output power	27-162 kW
Overall efficiency in VFI mode	>95%
Overall efficiency in ECO mode	99%
Audible noise level	65dB(A) full load (at 1 m)
Operating temperature range	UPS: 0°C - 40°C (50°C with de-rated loads)
Protection degree	IP20 (IEC 60529)
Standards	EN/IEC 62040, CE marking
EMC (Electromagnetic Compatibility)	EN/IEC 62040-2
Electrostatic discharge immunity	4kV contact / 8kV air discharge
Colour	RAL 9005 (Black)
External cable connections	Mid-rear, (Optional Front-bottom) and Top-bottom standard
Paralleling	Up to 3 units units for redundancy or capacity in RPA configuration (option)

RECTIFIER	
Standard input voltage	Nominal: 3x400V + N Programmable: 3x380 / 415V + N
Rectifier accepted ph-ph voltage range	Rectifier accepted ph-ph voltage range: 228* - 478V (low voltages acceptable with de-rated loads)
Input frequency	50/60 Hz +/-10% (45 ÷ 66 Hz)
Power factor	0.99
Input current THD	<3% at 100% load

\*conditions apply

BATTERY	
Battery type	Valve regulated lead-acid (VRLA)-standard, Vented lead-acid, wet battery and NiCd and Li-Ion
Float voltage at 20°C	436-545Vdc (dependent on the number of cells)
GE Battery Solutions	10 years design life VRLA batteries (EUROBAT)
Battery cold start	Available

INVERTER	
Nominal output voltage (on site programmable)	3x380V / 400V / 415V + N
Output frequency	50/60 Hz (selectable)
Output voltage tolerance: static	+/- 1%
Output voltage tolerance: dynamic (at load step 0 - 100 - 0%)	+/-1.5%
- Output voltage THD for 100% linear load	<1%
- Output voltage THD for 100% non-linear load (EN 62040)	<5%
Overload capability (at 25°C ambient temperature)	110% for 1 hour / 125% for 10 minutes / 150% for 1 minute / >150% for 200ms

BYPASS	TLE MODULAR SERIES 30 -180 (1 TO 6 MODULES) kVA
Overload on bypass	257A long term operation / 292A for 5 mins / 350A for 1 min. / 935A for 1s / >935A for 200ms
Primary components	Static switch (SCR) on bypass Electromechanic contactors (backfeed protection) on bypass and inverter manual switch for maintenance bypass

INTERFACING	
USB Port, RS232 serial port, RS 485 port, EPO, Customer Interface board	Standard
SNMP Card with iUPSGuard 1 year license	Included

PHYSICAL DATA	
Weights	Cabinet - 170kg, Power Module 30kVA - 34kg
Floor loading	309 (30kVA) - 566 (180kVA) kg/m <sup>2</sup>
Dimensions (WxDxH)	600x1100x1600mm

# LP33 Series - VFI Double-Conversion Transformerless UPS

3-phase CE, 10 - 20 - 30 - 40 kVA



## Overview

Designed as a true VFI (Voltage and Frequency Independent) UPS, the LP Series is an on-line double conversion, intelligent and heavy duty UPS. The VFI concept ensures the highest level of protection, even under the toughest conditions.

## Features and Benefits

- GE's clean input Active IGBT technology
- Multi-language LCD, easy to use
- Excellent overload behavior, withstands toughest conditions
- Cold start function (start-up without mains present)
- Manual bypass integrated in UPS
- Equipped with RS232 serial port
- Fits well in office environment
- Frequency converter

## Options

- SNMP Card
- GE Power Diagnostics
- Rectifier and/or bypass transformer
- Input THDI <4.5% for 60-80-100-120kVA
- Redundant Parallel Architecture
- MODBUS RTU Interface

## Function

Easy to install and service, the LP33 Series is optimized for office environments, but also suitable for more traditional, industrial applications.

## Typical Applications

- Computer and data centers
- Call centers
- Manufacturing and process control units
- Medical equipment and healthcare facilities
- Broadcast and satellite transmission systems
- Fixed and mobile voice and data transmission systems
- Emergency lighting systems
- Security systems
- Financial systems and services



## Standards & Certification

Safety: EN 62040 (EN 62050-1)

EMC: EN 62040-2

# Specifications

GENERAL DATA	LP33 SERIES 10 CE S6	LP33 SERIES 20 CE S6	LP33 SERIES 30 CE S5	LP33 SERIES 40 CE S5
Topology	VFI, double conversion			
Nominal output power	10kW	20kW	30kW	40kVA / 32kW
Overall efficiency in VFI mode	92.4%			
Overall efficiency in eBoost mode	98.6%			
Audible noise level	53dB(A)		60dB(A)	65dB(A)
Operating temperature range	UPS: 0°C - 40°C			
Protection degree	IP 20 (IEC 60529)			
Standards	EN/IEC 62040, CE marking			
EMC (Electromagnetic Compatibility)	EN/IEC 62040-2			
Electrostatic discharge immunity	4kV contact / 8kV air discharge			
Colour	RAL 9003 (white)			
Service access	Front and lateral (castors available on the bottom of the UPS)			
External cable connections	Bottom left			
Paralleling (RPA version)	Up to 4 units parallelable for redundancy or capacity in RPA configuration (optional)			

RECTIFIER	
Standard input voltage	Nominal: 3x400V + N Programmable: 3x380 / 415V + N Rectifier accepted ph-ph voltage range: 323 - 460V
Input frequency	50/60 Hz +/-10% (45 - 66 Hz)
Power factor	>0.98
Input current THD	<8%

BATTERY	
Battery type	Valve regulated lead-acid (VRLA)
Float voltage at 20°C	2x273Vdc

INVERTER	
Nominal output voltage (on site programmable)	3x380V / 400V / 415V + N
Output frequency	50/60 Hz (selectable)
Output voltage tolerance: static	+/- 1%
Output voltage tolerance: dynamic (at load step 0 - 100 - 0%)	+/- 3%
- output voltage THD for 100% linear load	<2%
- output voltage THD for 100% non-linear load (EN 62040)	<3%
Output frequency tolerance: free-running	+/- 0.1%
Overload capability (at 25°C ambient temperature)	125% - 10 minutes, 150% - 1 minute

BYPASS	
Voltage limits for inverter/ bypass load transfers	+/- 10% (adjustable)
Overload on bypass	200% for 2 min. and 1000% for 10 ms, non repetitive
Primary components	Static switch (SCR) on bypass Electromechanic contactors (backfeed protection) on bypass and inverter 2 Manual switches for maintenance bypass

INTERFACING	
RS232 serial port, EPO, Customer Interface board	Standard

PHYSICAL DATA				
Weight	140 Kg	150 Kg	195 Kg	200 Kg
Floor loading	359 Kg/m2	385 Kg/m2	379 Kg/m2	389 Kg/m2
Dimensions (WxDxH)	500x780x1320 mm		660x780x1320 mm	

# LP11/31T Series - VFI Double-Conversion Transformerless UPS

1-phase/3-phase in, 1-phase out CE, 3 - 5 - 6 - 8 - 10 kVA



## Overview

GE's LP11/31T Series is a single-phase UPS system based on true online double-conversion technology. Available in the power rating 3 (1-phase only), 5, 6, 8 and 10 kVA, the LP Series UPS provides you with the ultimate protection against any disturbances in the utility power such as surges, spikes, EMI noise, brown outs, black outs, etc. Using GE's unique Redundant Parallel Architecture (RPA) the LP Series UPS is suitable for mission-critical applications. The LP11/31T is tailored for multi-server environments, working with all common operating systems. The possibility for upgrade avoids the need for over sizing. Together with Superior Battery Management (SBM) this guarantees a favorable economic lifecycle.

## Features and Benefits

- **RPA**—Possible to connect output of up to 4 UPS in parallel
- **Superior Battery Management**—SBM enhances the battery lifetime providing the following
- **ECO-mode**—When ECO mode is selected, the LP11/31T operates continuously on bypass
- **On-board event logging**—All events such as mains failures, alarms, etc., are logged into the memory of the UPS
- **True on-line double conversion**—Maximum protection possible

## Function

LP11/31T Series—for your mission-critical equipment—is protected from any fluctuation in your power source, enabling you to concentrate on your core activities.

## Options

- SNMP Card
- Alarm Boxes
- RPA
- Battery Extension Packs

## Typical Applications

- Computer and data centers
- Call centers
- Telecommunications equipment
- Security systems
- Financial institutions
- Fixed and mobile voice and data transmission
- Security systems



## Standards & Certification

Safety: EN 62040 (EN 62050-1)

EMC: EN 62040-2



# Specifications

GENERAL DATA	LP11 SERIES 3kVA	LP11/31T SERIES 5kVA	LP11/31T SERIES 6kVA	LP11/31T SERIES 8kVA	LP11/31T SERIES 10kVA
Topology	VFI, double conversion				
Nominal output power	3kVA/2.4kW	5kVA/4kW	6kVA/4.8kW	8kVA/6.8kW	10kVA/8kW
Overall efficiency in VFI mode	89%				
Audible noise level	40 - 50dB(A)				
Operating temperature range	UPS: 0 °C - 40 °C				
Protection degree	IP 20 (IEC 60529)				
Standards	EN/IEC 62040, CE marking				
EMC (Electromagnetic Compatibility)	EN/IEC 62040-2				
Colour	RAL 9010 (white)				
Paralleling (RPA version)	Up to 4 units for redundancy or capacity in RPA configuration (option)				

3-1 CONVERTER (31T MODEL ONLY)	
AC input voltage range	230/400V +/- 15%
Input frequency range	45 - 65Hz

RECTIFIER	
Input Voltage	220 - 240V L + N
Input frequency	40 - 70Hz
Power factor	>0.99

INVERTER	
Nominal output voltage (on site programmable)	220/230/240V
Output frequency	50/60Hz (selectable)
Output voltage tolerance: static	+/- 1%
Overload capability (at 25°C ambient temperature)	110%: 20 min., 130%: 3.5 min., 150%: 2 min.

BYPASS	
Voltage limits for inverter/ bypass load transfers	+/- 10% of nominal
Frequency tracking range	+/- 2, 4 or 6% of nominal, selectable

INTERFACING	
RS232 serial port, EPO, Voltage free contact	Standard

PHYSICAL DATA					
Weight LP11	85 Kg	110 Kg	115 Kg	165 Kg	170 Kg
Weight LP31T	n.a.	180 Kg	185 Kg	270 Kg	275 Kg
Dimensions (WxDxH) LP11	313x590x537 mm			313x720x680 mm	
Dimensions (WxDxH) LP31T	n.a.	313x590x855 mm		313x720x995 mm	

BATTERIES RUNTIME	
With internal batteries (full load)	8-11 mins.
With extra battery pack (full load)	up to 80 mins.

# LP31 Series - VFI Double-Conversion UPS

3-phase to 1-phase CE, 8 - 10 - 15 - 20 kVA



## Overview

The LP31 Series 8 - 10 - 15 - 20 kVA UPS series is a compact, truly online 3-phase in 1-phase out system that incorporates the most advanced power electronics technology to provide exceptional protection for electrical equipment.

## Features and Benefits

- **Superior Battery Management**—Maximum uptime
- **ECO-mode**—High efficiency (97%), low energy costs
- **On board event logging**—Easy and fast diagnostics
- **Multi-lingual LC display**—Shows all operational parameters in several languages to choose from GB/NL/D/IT/ES
- **Design front**—Elegant design, fits with all modern ICT products
- **Emergency power off (standard)**—Emergency shutdown in case of fire or water alarms
- **Excellent Overload Behavior**—Withstands toughest conditions
- **Isolation transformer**—Ultimate protection from disturbances
- **Tracking speed is selectable**—Optimized for generator supply

## Function

LP31 Series—for your mission-critical equipment—is protected from any fluctuation in your power source, enabling you to concentrate on your core activities.

## Options

- SNMP Card
- Alarm Boxes
- Battery Extension Packs

## Typical Applications

- Computer and data centers
- Call centers
- Telecommunications equipment
- Security systems
- Financial institutions
- Fixed and mobile voice and data transmission



## Standards & Certification

Safety: EN 62040 (EN 62050-1)

EMC: EN 62040-2

# Specifications

GENERAL DATA	LP31 SERIES 8kVA	LP31 SERIES 10kVA	LP31 SERIES 15kVA	LP31 SERIES 20kVA
Topology	VFI, double conversion			
Nominal output power	8kVA/6.4kW	10kVA/8kW	15kVA/12kW	20kVA/16kW
Overall efficiency in VFI mode	92%			
Audible noise level	40-50dB(A)			
Operating temperature range	UPS: -10°C - 40°C			
Protection degree	IP 20 (IEC 60529)			
Standards	EN/IEC 62040, CE marking			
EMC (Electromagnetic Compatibility)	EN/IEC 62040-2			
Colour	RAL 9010 (white)			

RECTIFIER	
Input Voltage	3x300-470V + N
Input frequency	45 - 65Hz
Power factor	>0.95

INVERTER	
Nominal output voltage (on site programmable)	220/230/240V
Output frequency	50/60Hz (selectable)
Output voltage tolerance: static	+/- 1%
Overload capability (at 25°C ambient temperature)	120% >10 s, 150% >2 s

BYPASS	
Voltage limits for inverter/bypass load transfers	-15% +10% of nominal
Frequency tracking range	+/- 2, 4 or 6% of nominal, selectable

INTERFACING	
RS232 serial port, EPO, Voltage free contact	Standard

PHYSICAL DATA	LP31 SERIES 8kVA	LP31 SERIES 10kVA	LP31 SERIES 15kVA	LP31 SERIES 20kVA
Weight	240kg	240kg	345kg	350kg
Dimensions (WxDxH)	410x890x1190mm			

BATTERIES RUNTIME	
With internal batteries (full load)	up to 36 mins.
With extra battery pack	up to 123 mins.

# GT Series - VFI Double-Conversion UPS

1-phase CE, 6 - 10 kVA



## Function

GT Series—for your mission-critical equipment—is protected from any fluctuation in your power source, enabling you to concentrate on your core activities.

## Typical Applications

- Computer and data centers
- Call centers
- Telecommunications equipment
- Security systems
- Financial institutions
- Fixed and mobile voice and data transmission



## Standards & Certification

Safety: EN 62040 (EN 62050-1)

EMC: EN 62040-2

Environmental: RoHS, WEEE

## Overview

The GT Series is a true VFI (Voltage & Frequency Independent) on-line double conversion, transformerless, intelligent and high performance installable UPS. This UPS provides critical power protection to suit a wide range of IT Networks, Telecom and other applications. The GT Series is easy to install and service, and is designed for maximum site flexibility. With an attractively designed modern common tower and/or 19inch rack mount cabinet, the UPS can adapt as network configurations adapt. Both the power and redundancy of the system can be expanded by adding units (N+2) to create a parallel system.

For communication, the GT Series is equipped with RS232 and contact interface as standard; a web-enabled SNMP card is available as an option. Operation in remote or unmanned sites is simple to coordinate with the standard remote monitoring functionality. No load shutdown, automatic frequency detection, settable minimum start-up runtime and extended runtime availability with optional battery packs are additional features of the GT Series UPS.

## Features and Benefits

- Online double-conversion technology assuring ultimate power quality
- Remote controlled, programmable computer shutdown
- Combined tower/rack for maximum flexibility
- Wide input voltage window to minimize battery operation
- Small footprint and low weight, ideal for IT applications or sites with limited available space
- Hot-swappable batteries for easy replacement without dropping the load
- Simple installation of paralleling cable for expanded power and redundancy of the system
- Backfeed protection providing optimal safety for installation
- Frequency converter (50Hz – 60Hz) also in parallel operation
- All components for rack, tower and parallel installation are included with the UPS

## Options

- Battery Extension Packs—The paralleling cable delivered with each GT Series UPS allows you to connect up to 3 UPS in the same power rating together in a parallel system
- SNMP Card—An SNMP card may be inserted into the proper plug to allow UPS data communication over an Ethernet network or web
- Rack Kits

# Specifications

GENERAL DATA	GT SERIES 6000	GT SERIES 10000
Topology	VFI, double conversion	
Nominal output power	6000VA/4200W	10000VA/7000W
Overall efficiency in VFI mode	92%	
Audible noise level	<55dB(A) (load and temperature dependent)	
Operating temperature range	0-40°C (15-25°C recommended for batteries)	
Protection degree	IP 20 (IEC 60529)	
Standards	EN/IEC 62040, CE marking	
EMC (Electromagnetic Compatibility)	EN/IEC 62040-2	
Electrostatic discharge immunity	IEC/EN 61000-4-2, Level 4, 8kV contact / 15kV air discharge	
Colour	RAL 9005 (black)	
Paralleling (RPA version)	Up to 3 units for redundancy or capacity in RPA configuration (option)	

RECTIFIER	
Input voltage range	84-276 V
Input frequency	40-70 Hz
Power factor	>0.97

INVERTER	
Nominal output voltage (on site programmable)	220 / 230 / 240 (selectable)
Output frequency	50/60 Hz (selectable)
Output voltage tolerance: static	+/- 2%
Overload capability (at 25°C ambient temperature)	125% - 1 minute, 150% - 10 seconds

BYPASS	
Voltage limits for inverter/bypass load transfers	+/- 10% nominal
Transfer time	0.5 ms typical

INTERFACING	
RS232 serial port, RPO, Parallel Board	Standard

PHYSICAL DATA	GT SERIES 6000	GT SERIES 10000
Weight	23.5 + 66.5 Kg	
Dimensions (WxDxH), tower orientation	130(3U)x660x410mm	

BATTERIES RUNTIME	
With internal batteries (full load)	up to 12min
With extra battery pack (full load)	up to 47min

# VH Series - VFI Double-Conversion UPS

1-phase CE, 700 - 1000 - 1500 - 2000 - 3000 VA



## Function

Providing exceptionally reliable protection for electrical equipment.

## Typical Applications

- Mission-critical servers
- Local area networks
- Laboratory devices
- Internet servers
- Network components
- Telecommunication equipment
- Process and telecom industry equipment
- Wind Turbines

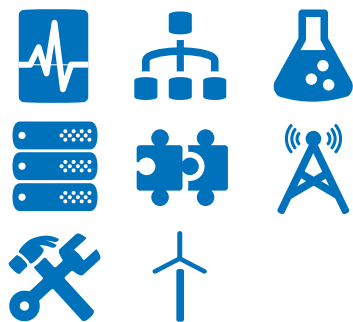

## Standards & Certification

Safety: EN 62040 (EN 62050-1)

EMC: EN 62040-2

## Overview

The VH Series is a true VFI (Voltage & Frequency Independent) on-line double conversion, intelligent and high-performance UPS designed for all mission-critical applications. The UPS range is designed with a unique failsafe bypass providing maximum security and reliability for the user.

The VH Series has been designed also for maximum site flexibility. With an attractively designed modern common tower and/or 19inch rackmountable design, the UPS can adapt as network configurations adapt.

For communication, the VH Series is provided with USB and contact interface as standard; an easy to install option card is available with RS232, USB and relay. A web-enabled SNMP card is available as an option.

## Features and Benefits

- Unique failsafe internal bypass for continued operation even in the event of UPS failure
- Tower and/or 2U rack design for all ratings; all support elements included
- Simple battery replacement without disruption to supported load
- Versatile communication with USB and contact interface, RS232, relays and SNMP
- Wide input voltage window minimising battery usage
- Excellent short circuit protection
- GE's unique Superior Battery Management enhancing battery performance and lifetime
- Easy plug-in connection of battery packs for extended run-time
- Remote monitoring and control for unmanned or isolated sites
- Can be used as a 50/60Hz frequency converter
- Phase neutral reversal protection
- High overload capability
- Precise output frequency regulation
- High efficiency

## Options

- Battery extension packs can be connected to obtain extended run-time (not on VH700VA)
- Plug-in communication card easy-to-install option cards with either RS232-USB-Relay or with SNMP functionality
- Supporting Rail Rack-mount Kit to properly support the UPS when mounted in 19 inch rack
- Maritime kit to further strengthen the UPS in harsh maritime environments with high vibrations and poor mains quality

# Specifications

VH CE SERIES MODEL	VH700	VH1000	VH1500	VH2000	VH3000
Voltage Amperes (VA) with computer type load	700	1000	1500	2000	3000
Watts (W) with resistive load	490	700	1050	1400	2100
Input thermal circuit breaker (A)	7	7	8	10	16
Internal input fuse 250V, slow (A)	8	8	10	16	20

INPUT CONVERTER					
AC input voltage	220 - 240 V				
AC input voltage range	100% load: 160 - 280 V 70% load: 130 - 280 V input >280 Vac: UPS switches to battery operation				
Minimum start-up AC voltage	170 V (at any load)				
Input current waveform	sinusoidal, conform or better than EN 61000-3-2 (IEC 555-2)				
Input current (A) at nominal input voltage	3	4.4	6.4	8.8	13.1
Input power factor	1				
Input frequency range	45 - 66 Hz				
Inrush current	none				

OUTPUT CONVERTER	
AC output voltage	220 / 230 / 240 V (selectable)
AC output voltage tolerance	± 2%
Output frequency	auto selectable 50 or 60 Hz
Output frequency range	nominal ± 0.15%
Output waveform	sine wave
Harmonic distortion	< 2% (typical 1%) with linear load
Power factor	0.7
Crest factor (peak to RMS current)	suitable for loads with c.f. up to 6:1
Capacity appliance outlets	max. 10 A per outlet (one 16A outlet on VH Series 3000 VA)

BYPASS	
AC input voltage range	selected output voltage +15% -10%
Frequency tracking rate	2 Hz/sec.
Frequency tracking range	nominal ± 10% / ± 2% selectable
Phase difference	< 7°
Typical transfer time, msec	1

OVERLOAD CAPABILITY	FULLY PROTECTED AGAINST OVERLOAD AND SHORT CIRCUITS
Overload behaviour during battery operation	110% during 5 minutes 150% during 5 seconds
Overload behaviour during bypass operation	depends on rating of thermal circuit breaker typical: 125% of TCB value for 200 seconds typical: 200% of TCB value for 10 seconds typical: 300% of TCB value for 4 seconds

PHYSICAL DATA	VH700	VH1000	VH1500	VH2000	VH3000
Weight	18.3kg		19.3kg	31.3kg	33.3kg
Dimensions (WxDxH), tower orientation	87(2U)x472x440mm		87(2U)x547x440mm		

# VCO Series - VFI Double-Conversion UPS

1-phase CE, 1000 - 2000 - 3000 VA



## Function

Ensuring a continuous supply of clean, conditioned power to all critical loads, protecting against system interruption, data corruption and data loss.

## Typical Applications

- PCs
- Servers
- Mid-sized networks
- Laboratory devices
- Voice/data networks
- Telecom
- Light industrial

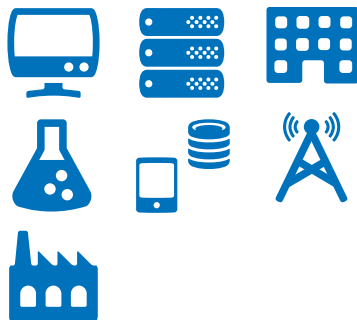

## Standards & Certification

Safety: EN 62040 (EN 62050-1)

EMC: EN 62040-2

Environmental: RoHS, WEEE

## Overview

GE's VCO Series Uninterruptible Power Supply (UPS) is a true double-conversion Voltage and Frequency Independent (VFI) UPS, providing the highest level of protection to all loads. Regardless of the quality of power from the grid, the VCO Series will create a brand new sine wave with a fully regulated voltage and frequency; the supported load receives a constant, moderated supply. When the grid power fails, the battery seamlessly steps in to continue the supply and allow for enough time to finish the current process before initiating an automatic shutdown of the load until the mains returns.

## Features and Benefits

- High operating efficiency >95% in high efficiency mode, reducing emergency and operational costs on site
- Multiple outlets for all ratings; several pieces of equipment can be connected to the VCO Series without adding PDUs or extension strips; one set of outlets can be programmed to switch off in order to increase the remaining runtime
- Rack and/or tower format in a single cabinet; as network demands change, the VCO Series can adapt
- Automatic battery test makes a periodic health check of the batteries, ensuring battery availability

## Options

- Battery extension packs can be connected to obtain extended run-time
- **Plug-In SNMP card option**  
Available as an option, supporting all major operating platforms. The UPS can be monitored and managed across a network, with web enabled SNMP configuration for full visibility of UPS operation from any location.



## Specifications

MODEL/CAT. NO. REF NO.	VCO1000 25930	VCO2000 25931	VCO3000 25932
Rating VA/W	1000/800	2000/1600	3000/2400
AC input voltage	208/220/230/240 Vac		
AC input voltage, window	120 - 280 Vac		
Frequency	50/60 Hz (auto-sensing)		
Input power factor	>0.95 at full load		
AC output voltage	208/220/230/240 Vac (selectable)		
Output frequency	50/60 Hz (selectable)		
Output wave factor	sine wave		
Output power factor	0.8		
Harmonic distortion	3% at linear load		
Efficiency (ECO Mode)	>95%		
Number of outlets (programable)	4(2)	6(3)	
Runtime at typical load (60%) minutes	7	8	
Weight (kg)	16	32	38
Dimensions (WxDxH, mm), rack	440x405x88	440x620x88	
Display type	LCD - Liquid Crystal Display		
Safety	IEC/EN 62040-1		
EMC	IEC/EN 62040-2		
Ambient temperature	0°C to 40°C		
Maximum relative humidity	95% (non-condensing)		



# VCL Series - Line Interactive UPS

1-phase CE, 400 - 600 - 800 - 1000 - 1500 VA



## Overview

GE's VCL Series UPS offers continuity in a compact, lightweight and cost-effective solution. The VCL Series range of UPS connects between the mains supply and your critical load to ensure—when the mains power drops or fails—your load continues to receive a clean, constant and reliable source of power until a safe shutdown of the load can be performed. Hardware and data are protected and operations are reliably maintained.

## Function

Providing exceptional cost-effective protection for electrical equipment that is not mission-critical.

## Typical Applications

- PCs, servers, networking peripherals
- Small networks
- Transportation systems
- CCTV, EPOS, ATMs
- Petrol pumps
- Parking meters

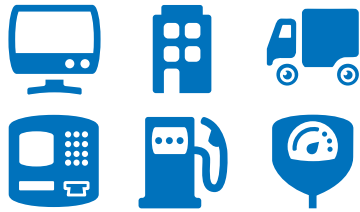

## Features and Benefits

- High operating efficiency >95% is standard to minimize losses and reduce cooling costs
- Both power protection and surge protection outlets ensure that critical loads are closed down in a safe, controlled manner in the event of an extended mains failure; surge protection outlets provide power conditioning to less critical loads. Additional surge protection for data lines is provided
- Automatic shutdown software is provided free of charge with every UPS
- Automatic voltage regulation (AVR) corrects voltage drops and surges coming from the mains without the UPS resorting to battery; battery life is maximized and the user is still ensured consistent power to the load

## Options

### • Plug-In SNMP card option

Available as an option, supporting all major operating platforms. The UPS can be monitored and managed across a network, with web enabled SNMP configuration for full visibility of UPS operation from any location.

## Standards & Certification

Safety: EN 62040 (EN 62050-1)

EMC: EN 62040-2

Environmental: RoHS, WEEE

## Specifications

MODEL/CAT. NO. REF NO.	VCL400 25921	VCL600 25922	VCL800 25923	VCL1000 25924	VCL1500 25925
Rating VA/W	400/250	600/360	800/480	1000/600	1500/900
AC input voltage	170 - 280 Vac				
Frequency	50/60 Hz (auto-sensing)				
Battery type	12V, sealed lead acid, maintenance free				
Numberxcapacity of battery	1x4.5 Ah	1x7 Ah	1x9 Ah	2x7 Ah	2x9 Ah
Runtime at typical load (60%), minutes	5	6	6	8	6
Battery recharge time	8 hours				
Modem / phone / fax protection	RJ11				
Communication port	USB				
Ambient temperature	0°C - 40°C (32°F - 104°F)				
Maximum relative humidity	95% (non-condensing)				
Storage temperature	-15°C - 55°C (5°F - 131°F)				
Net weight (kg)	4.0	4.6	5.6	8.4	10.3
Dimensions (WxDxH, mm)	112x222x220			112x330x220	
Safety	EN 62040				
EMC	EN 62949 -2				
Compliance	RoHS, REACH, WEE				
Number of outlets	6 pcs IEC - 320 C13 outlets			7 pcs IEC-320 C13	



# UPS Key Features/Capabilities

## Providing Reliable Power to Your Mission-Critical Business Needs

With a comprehensive energy management portfolio, GE is uniquely positioned to provide industrial, commercial and datacenter infrastructure solutions. GE is a global solutions provider modernizing and optimizing how we generate, move and consume energy. We invent, improve and integrate communications, automation and power delivery technologies to enable cleaner, smarter and more efficient power for electrical infrastructures and consumers around the world.

Here are just a few of the innovative features and capabilities found across GE's Critical Power product line.

## Ultra-High Efficiency with eBoost™

Energy consumption is a critical issue for IT organizations as their datacenter energy demands continue to grow. Their goal is to reduce cost while ensuring power continuity. IT organizations can reduce energy consumption costs without sacrificing system reliability with GE's eBoost technology.

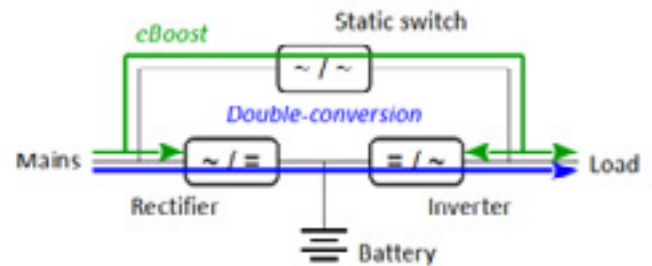

### Technology Features

- Up to 99% UPS efficiency
- Compliant to ITI (CBEMA) curve during transient events
- Continuous adaptive monitoring of instantaneous output voltage during eBoost operation
- Proprietary (patented) digital algorithms ensures prompt disturbance detection, triggering transfer to inverter
- Patented power electronics and magnetics ensures less than 2ms transfer time to inverter
- Proprietary (patented) fault detection and selective reaction based on fault location
- Patented power conditioning/filtering design via bypass inductor and output transformer/capacitor while in eBoost mode
- Transformer-less UPS may be configured for actively conditioning voltage quality and reactive power during eBoost operation
- Battery trickle charge in eBoost operating mode
- Up to 3 MW UPS capacity using paralleled modules

### What is eBoost?

e = high efficiency up to 99%

Boost = fast transfer to inverter < 2ms

### Customer Benefits

- 80% reduction in UPS losses => System energy cost savings
- Reduced heat (BTU) generation => Energy savings from reduced cooling
- Overall efficiency improvement => Reduced CO2-equivalent emissions
- Reduced stress on UPS components => Enhanced reliability

### eBoost Performance

Output voltage is continuously monitored during eBoost operation. An adaptive digital algorithm ensures fast detection of power quality events, promptly transferring to inverter operation: transfer time <2ms.

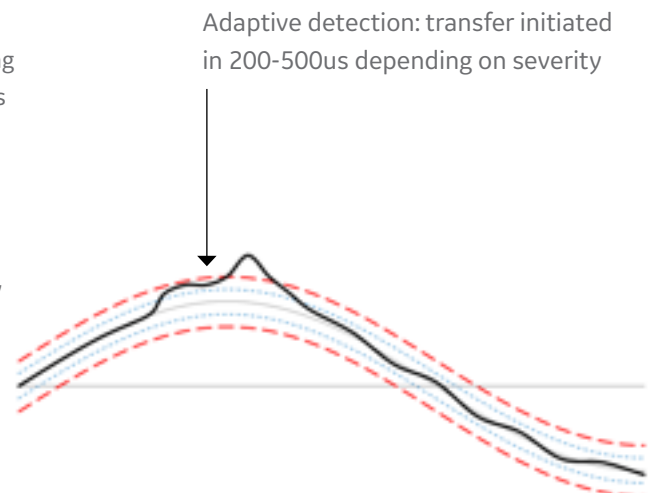

## CBEMA Curve

The ITI, formerly CBEMA, curve was developed by the Information Technology Industry Council of the United States of America. The curve describes an AC input voltage envelope which typically can be tolerated by most Information Technology (IT) Equipment.

The ITI (CBEMA) Curve describes both steady-state and transitory conditions. Below the most common Power Quality events are mapped to the curve, with details of eBoost typical reaction.

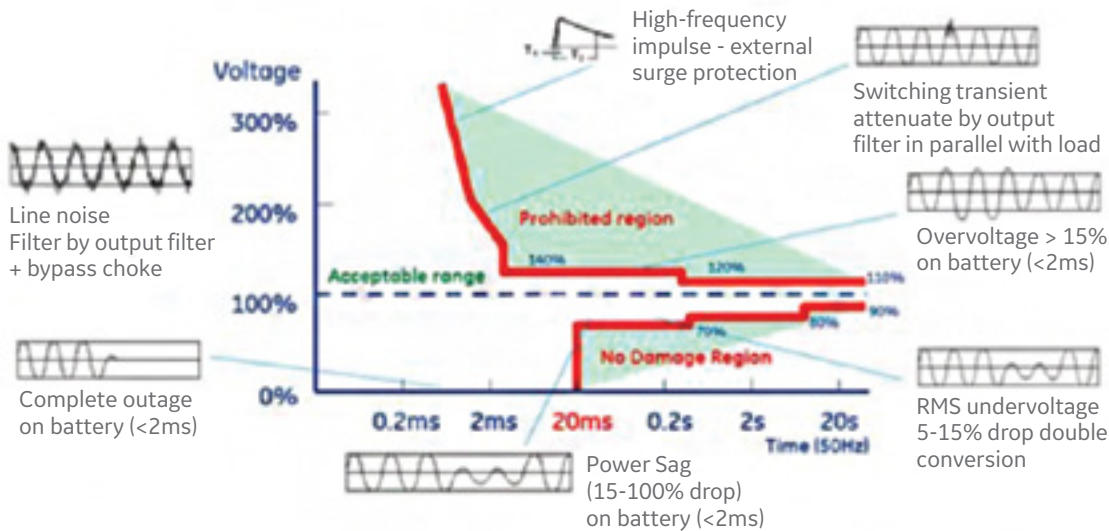

## eBoost vs ITI (CBEMA) Curve

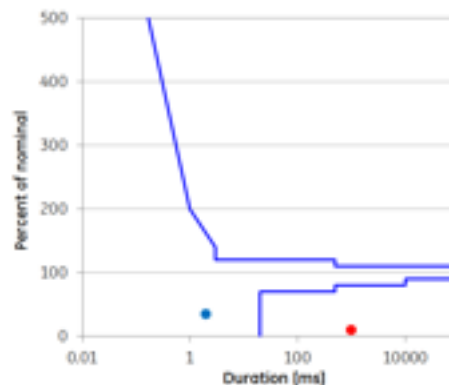
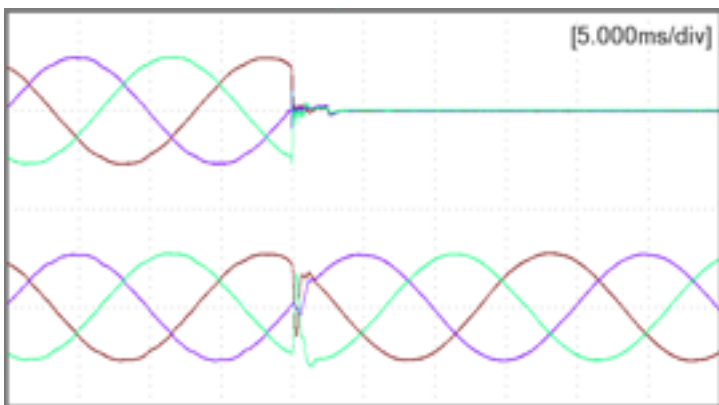

Example: 3ph Power Outage, input voltage (top) vs. output voltage (bottom) and ITI (CBEMA) plot (right), red dot AC input event, blue dot corresponding AC output event

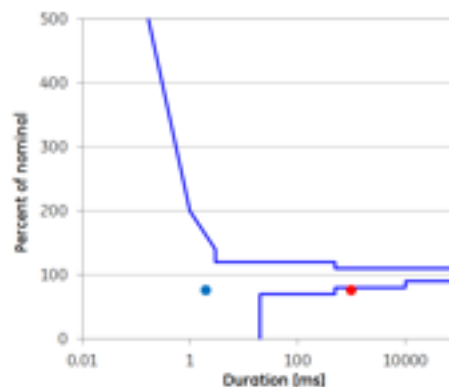
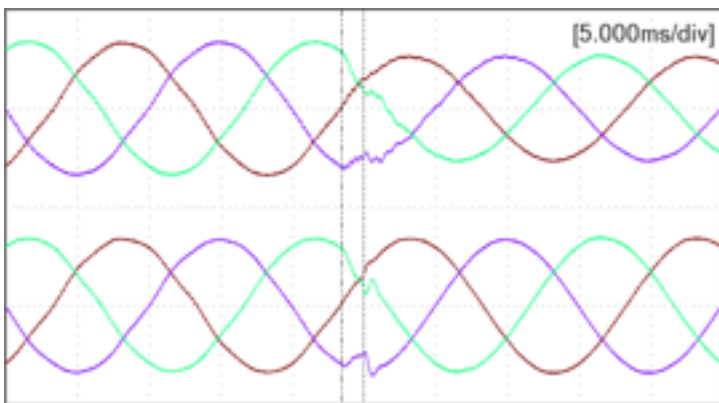

Example: 3ph Sag (-20%), input voltage (top) vs. output voltage (bottom) and ITI (CBEMA) plot (right), red dot AC input event, blue dot corresponding AC output event

## eBoost and Harmonics

Non-linear loads may inject current harmonics into the power system. Such distorted current produces voltage distortion given the voltage drop over the series impedance of the power source. Double-conversion UPS de-couple input and output AC systems, thereby shielding the upstream power system from downstream non-linear loads. GE proprietary implementation offers power conditioning and harmonic mitigation also during eBoost operation.

### eBoost on SG Series UPS

In SG Series Transformer UPS the inverter output filter is energized during eBoost operation, and it can therefore provide some degree of current conditioning. Particularly:

- The inverter filter capacitance may provide displacement power factor correction for inductive (lagging power factor) loads
- The inverter output transformer features a zigzag (interconnected star) secondary winding, acting as a current triplen harmonics trap. Load neutral current resulting from non-linear and/or unbalanced load is trapped in the zigzag winding, yielding load balancing and harmonic mitigation towards the upstream power system
- The effectiveness of the power conditioning offered by the inverter output filter is magnified by the bypass series choke. On average, neutral current injected in the upstream power system is reduced to less than half the downstream load neutral current

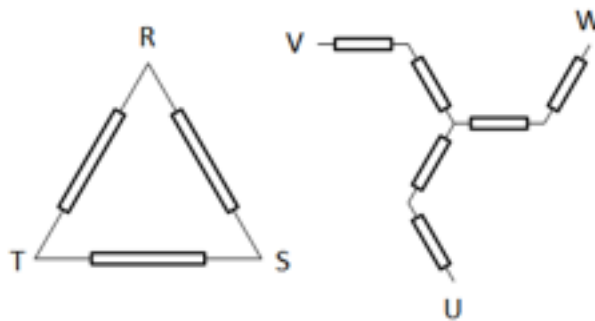
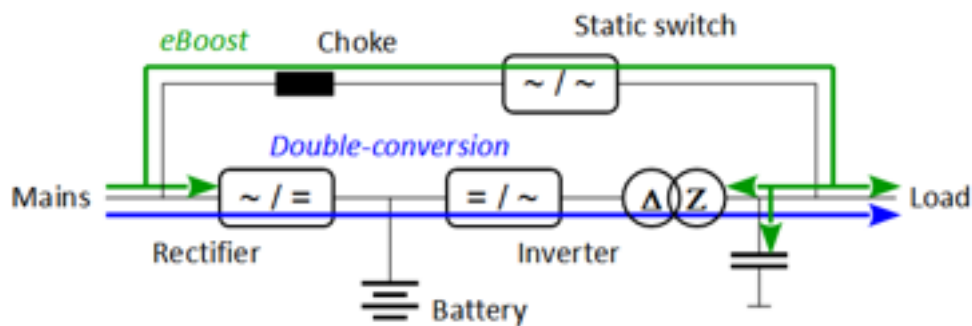

## eBoost on TLE Series UPS

Power conditioning is available also in eBoost operation of TLE Series Transformerless UPS. Here, double-conversion power converters may be configured for actively conditioning voltage quality and reactive power during eBoost operation. Particularly:

- The inverter filter capacitance may provide displacement power factor correction for inductive (lagging power factor) loads. At the same time, the power converters may be configured to compensate the output filter reactive power for capacitive (leading power factor) loads
- The power converters may also be configured for mitigating line voltage distortion, thereby indirectly mitigating load current distortion, using a proprietary conditioning technique (patent pending)
- Active conditioning does not penalize efficiency; additional losses typically around 0.1% of UPS rating

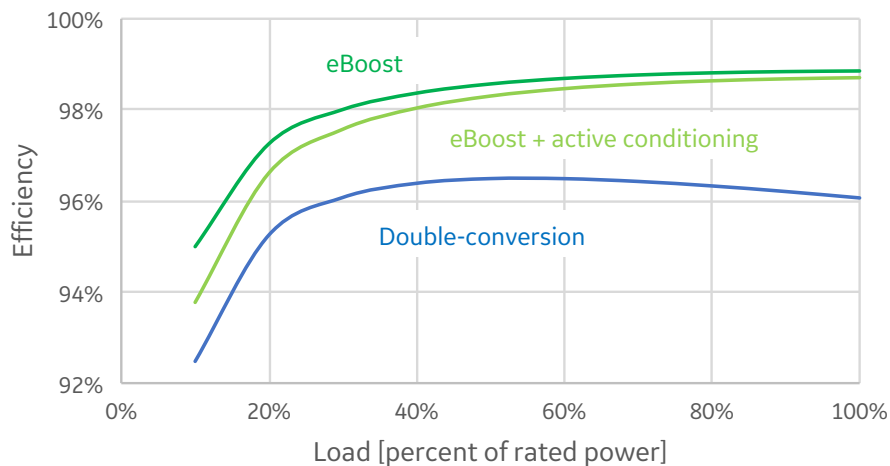
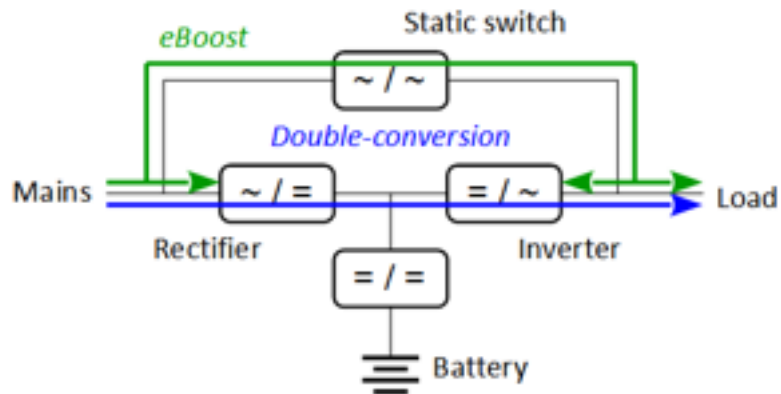

### Customer Benefits

- Power quality improvement by mitigating voltage and current distortion
- Displacement power factor correction and/or reactive power compensation
- Improvement of eBoost availability, thereby enhancing high-efficiency operation

# Redundant Parallel Architecture™ (RPA) System Configuration

GE provides RPA, a unique technology that can parallel UPS modules with true redundancy by eliminating any single point of failure. RPA provides a scalable paralleling technique that reduces operating footprint and increases system reliability by eliminating the need for external paralleling equipment and cabinets (centralized bypass and master control).

One of the UPS modules in the system intelligently takes the leadership role, while the other UPS modules have access to all control parameters. If one UPS fails to operate, the load is automatically redistributed among the others. If the lead UPS fails to operate, then another UPS automatically takes on the leadership role. GE's RPA technology is implemented by distributing the control electronics within each UPS module in the system.

## RPA System Advantages

- **No Single Points of Failure**—The RPA system provides complete redundancy of all critical components, allows paralleling of up to 6 units for increased load capacity or redundancy.
- **Bypass Inductor Design**—Ensures excellent output voltage regulation between paralleled modules and assists bypass line conditioning (eBoost only). Bypass inductor design & RPA cable saver available only for eBoost unit 160-500 kVA.
- **Scalable and Modular**—The system can be easily expanded for higher capacity and redundancy without any interruption to the critical load or transfer to bypass.
- **Distributed Control Logic**—Each module in an RPA system has its own operational controller. Each one continuously communicates with all others in order to manage the entire system like a team.
- **Redundant Communication**—Redundant high speed bus and control electronics provide higher system reliability.
- **Online Maintenance**—N+1 configurations allow maintenance on any single module in the system while other modules provide online protection with battery backup.
- **Sequential Soft Start**—Provides sequential soft start of each module to reduce instantaneous load on input feeders during mains recovery. This helps avoid over-rating of generator and overheating of cable and fuses.
- **RPA Cable Saver**—UPS Module input and output cable length variation up to 10% between modules. With eBoost technology this cable length flexibility is increased up to 25% between modules.
- **Smaller Footprint**—RPA eliminates centralized control and external static bypass cabinet.

## Standard RPA™ Configuration

True Redundancy with Distributed Control & Bypass

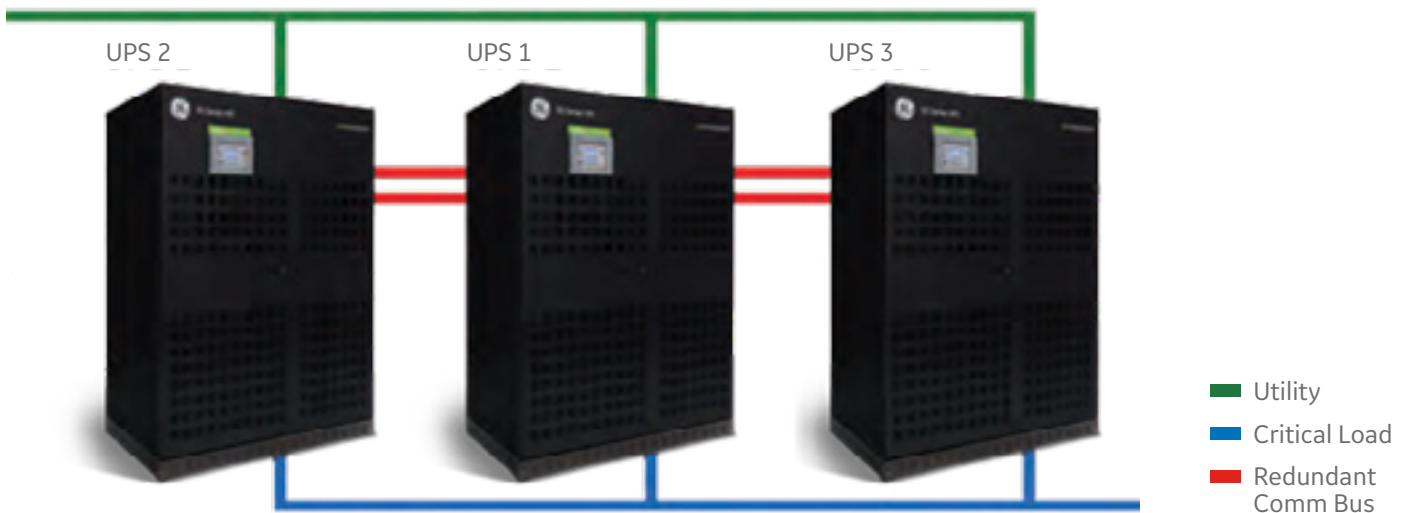

### Configurable up to 6 units in parallel

- Future expansion
- Safe and reliable power supply
- Redundant Communication Bus

### Easy to install and maintain

- Easy system upgrade/downgrade
- Maintenance operation without load interruption



# Intelligent Energy Management Integrated (IEMi)

GE's Intelligent Energy Management integrated (IEMi) operating mode offers the capability to optimize and increase system efficiency while maintaining the system reliability for UPS's in a redundant parallel architecture (RPA™).

UPS system sizing accounts for normal load requirement, overload and capacity for future expansion. In addition, redundancy level of N+1 or N+2 is considered to enhance system reliability.

Most UPS systems typically operate at low load levels <50%. At load level of less than 30-40%, efficiency of UPS decreases in comparison to normal operating load range of 40%-75%. In redundant parallel architecture (RPA™) system of 4 UPS modules its more efficient to have 2 UPS operating at 40% load range than 4 units operating at 20% load range.

For parallel UPS installations, IEMi operating mode saves energy by dynamically utilizing the UPS modules as needed to meet the required output power without compromising power quality to the critical load.

## Features

- User programmable scheduling
- Inverter test at regular intervals
- Front graphic panel accessible setpoints
- SNMP communications

## Benefits

- Reduction in UPS losses
- System energy cost savings
- Energy savings from reduced cooling
- Double conversion operation - no compromise on power quality
- Redundant operation - no compromise on system reliability
- Cyclic operation ensures even UPS run-time

## IEMi Configuration

Configuration of the IEMi is very easy: it can be done through the graphic display of one of the UPS units or via the SNMP/Web adapter (web interface). The IEMi activation can be controlled on calendar (Weekday/Time).

## IEMi Operation

- IEMi operation is controlled by the UPS Control Board making full use of the RPA peer-to-peer architecture (no external hardware control required)
- Redundancy level in IEMi mode: N+1, N+2 (suitable for RPA installation of 3 or more UPS)
- Efficiency optimization
  - UPS control board monitors load demand
  - Ensures selected redundancy level
  - Adaptive capacity control to provide maximum efficiency
- In case of a mains failure: all UPS ON
  - Maximize battery autonomy
  - Best fault-clearing capability

## IEMi Savings

Use of IEMi can enhance the system efficiency by ~ 3% for 4x500 kVA UPS running at 10% load range, maintaining N+1 redundancy level. This can save up to \$ 8,712\* annually in energy cost savings from reduction of UPS losses and saving in cooling cost.

### \* Assumptions:

- 4x500 kVA UPS
- Redundancy level of N+1
- Energy costs = \$0.11/kw-hr
- Cooling costs = 0.5xUPS heat loss cost

# Connectivity Solutions for UPS

## UPSMAN & RCCMD Data Protection Software

GE's UPS come standard with two software packages:

### UPSMAN and RCCMD

UPSMAN is a complete protection software providing a graphical interface for monitoring the UPS. It communicates with the UPS via the standard RS232 interface or via an optional SNMP plug-in card. If the UPS is not able to supply the required power the software enables the computer on which it is installed to shutdown gracefully in order to avoid data corruption. UPSMAN can also act as a "master computer" which can send remote shutdown commands to multiple remote computers/servers in case of a UPS failure. These remote computers/servers, centrally controlled by a computer running UPSMAN, need to run on their turn the light software package named RCCMD.

### UPSMAN - Description

- Data Protection Software
- Supports RS232 , USB & SNMP communication
- Free software license
- Written in native language
- Supports most popular OS, including virtualization

### RCCMD - Description

- Light background protection software
- Native solution for more than 35 OS
- React on shutdown commands

### SNMP Web Adapter

As an alternative for the solution above, with a "master computer" controlling multiple remote computers in a network, the UPS can be equipped with an SNMP card. This card sends the required remote shutdown commands directly to the remote network computers, which again all run the software RCCMD.

### SNMP Web Adapter features

- SNMP Adapter - makes all UPS information available on a computer network (Ethernet)
- Complies to the standard UPS-MIB (RFC1628)
- Common firmware and graphical interface for all Web Adapters
- Easy firmware update via network (ftp)
- Multiple rights for user accounts
- Direct e-mail service configurable via web browser
- Shutdown command up to 30 remote servers
- Download UPS Parameters & events (4000 / 9000)
- Built-in HTTP-server
- Provides data of each UPS connected to RPA
- New functionalities available with software updates NO HW changes required!

### Modbus TCP

- UPS values as signed integer or Floating 32bit
- Easy configuration via Web Interface
- License activation based on card MAC address
- UPS alarms, measures and status monitoring for all UPS in RPA

### Bacnet IP

- Communication protocol for Building Management Systems
- Defines a number of data link available, such as Ethernet IP
- UPS metering, alarms and status messages
- Implemented Ethernet Physical layer



# Monitoring & Predictive Analytics

## GE's Battery Monitoring System

If you're operating mission critical systems relying on the protection of a UPS and battery bank, battery monitoring is essential. It's about peace of mind – knowing that the batteries are healthy and being constantly monitored. Knowing that everything has been done that can be done, to protect your enterprise from the consequences of a power failure.

## All batteries will fail, it is just a matter of time

It only takes the failure of one battery to compromise the entire battery string. It is often assumed that batteries are meticulously maintained, but this is rarely so. Many batteries are not inspected or maintained beyond an annual UPS service visit. Unknown and undetected battery failures become apparent right at the time when you need the batteries the most – during a mains failure.

UPS systems provide only rudimentary battery monitoring. The UPS cannot identify faults within individual batteries, nor detect an imbalance in the performance of multiple strings. To ensure the integrity of the battery system, it is necessary to detect failing blocks before they affect the performance of the entire system. The effectiveness of a battery monitoring system is proportional to the number of points that are monitored and the frequency that this occurs. With regular monitoring comes the accumulation of data, the ability to report and spot trends, and the ability to take timely remedial action.

GE's Critical Power business provides the most advanced and most cost-effective tool for monitoring and managing stand-by battery banks. GE's continuous data sampling, reporting and battery management capability delivers reduced costs, gives peace of mind, and most importantly - ensures that you have batteries that perform when needed.

## Critical Power – when and where it matters the most

GE is trusted throughout the world to help protect the power supply of data centres, banks, hospitals, telecommunications operators, and a wide range of major commercial and industrial enterprises.

The GE Battery Monitoring System takes a modular approach to battery monitoring. This means that by selecting from a range of options, the system can be tailored to meet your specific requirements. Maintenance free VRLA or wet cells, lead acid or Nicad - Critical Power has a solution for your battery.

## Understanding your batteries

### Individual battery voltage

Incorrect charge voltages may result in loss of capacity, accelerated grid corrosion, excessive gassing and premature end of life. Voltage also identifies catastrophic failures, such as short circuit cells, and gives true visibility of performance under discharge.

### Ambient temperature

A battery's life-span is normally specified at 20 or 25 degrees centigrade. Temperatures outside of the specified range can significantly affect the battery's corrosion rate, and therefore the life of the battery. An 8-10deg temperature increase can decrease battery life by 50%.

### String current

String current monitoring measures the energy delivered or accepted by each battery string. A UPS will only measure total current and cannot detect imbalances between strings. An imbalance highlights potential problems within a battery string. String current measurement also allows detection of incorrect battery charging and any significant earth leakage faults.

### Total string voltage

Tracking the string voltage confirms the charger is on and performing correctly.

## Individual battery impedance (ohmic value)

The impedance of a battery will increase with age. High impedance results in a battery that cannot supply the required current – its key task. High impedance also highlights poor connections and open circuit batteries before failure. Batteries can fail in a very short period of time (less than a week) so measuring impedance daily allows you to detect faulty batteries without the need to discharge them. By trending impedance you can accurately determine the end-of-life of the battery.

## Battery temperature

Measuring the temperature of each battery highlights localised environmental problems through poor HVAC.

It can also highlight poor connections and excessive charger ripple. Temperature is a critical parameter for NiCad batteries. Most importantly, battery temperature measurements allow the early detection of thermal runaway.

## The financial benefits

By definition, wherever there is a bank of batteries, there is a mission-critical environment being protected. It follows that if the batteries are unable to perform when they are needed, the consequences and costs are going to be serious. Power failures happen all too often and at a time like that the investment in the UPS, battery bank and battery monitoring system needs no further financial justification.

However, even in day-to-day operation, GE battery monitoring provides a strong return. The following cost savings are worth considering:

- Fewer batteries to purchase - through extending the service life of the ones installed.
- Reduced manpower – through automation & reduced number of discharge tests.
- Reduced call-out charges – through effective preventive maintenance.
- Planned battery purchasing – through avoiding emergency replacements.
- Reduced travel and time – through remotely accessing status data.
- Successful warranty claims – through having documentary evidence.
- Reduced insurance premiums.

## Battery Monitoring features

- 24/7 alarm notification.
- Automatic capture and recording of data during float, charge & discharge.
- Rapid voltage sampling - all batteries simultaneously every 4 seconds.
- Planned battery purchasing – through avoiding emergency replacements.
- Built in intelligence for battery state recognition and comparable impedance readings.
- Temperature compensation.
- User defined alarm limits.
- On-board memory.
- 750 VDC optical isolation.
- VRLA, VLA, Nicad.
- Flexible to suit battery model & application.

## Link battery management software

- Proactive management tool
- Real time battery status
- Alarm & activity log with on-screen pop-ups and email alerts
- Live discharge display
- Automated data management
- Battery history database for life trending
- Point & click report generation

## Data presentation is the key for efficient management

A single battery monitoring system can monitor up to 1,280 batteries. Connecting multiple systems via GE IS Link battery management software gives visibility to an unlimited number of batteries from a single desk.

## Critical Power offers:

- WAN/LAN integration for remote monitoring via Link software.
- RS 232 connection for local battery service & diagnosis.
- SNMP or Modbus interface to Building Management Systems.
- Dry contacts for alarm output.



# iUPSGuard

## Remote Monitoring Solution for UPS

GE's iUPSGuard solution is an anytime, anywhere concept in UPS status monitoring and alarm notification supporting all GE UPS product lines.

## Securing Critical Power

GE's iUPSGuard is a remote monitoring solution for UPS, providing status monitoring and alarm notification that supports all GE UPS product lines, anytime, anywhere. iUPSGuard provides current and detailed information about UPS operation, including its configuration, internal alarms and operating conditions over web. iUPSGuard notifies personnel of critical alarms and events via email or SMS, allowing a user or GE technician to make timely decisions on critical conditions. In addition, comprehensive data collection and analysis improves diagnostics capability and enhances response time. Continuous monitoring and ongoing maintenance help ensure maximum performance of your UPS equipment as it protects business critical applications.

## Key Features

### Safe and Secure

- Highly secure and efficient data transmission
- SSL encrypted unidirectional communication
- Firewall friendly – no changes required to firewall settings or proxy servers providing easy deployment and addressing compliance objectives

### Flexible Communication Options

- Supports various communications including IP and GPRS
- Alarms notification through email and SMS
- Monitoring third party UPS products via SNMP (standard RFC1628)

### 24x7 UPS Status and Monitoring

- Optimized data transmission helps ensure the latest and most up-to-date information is available
- Alarms and other critical events are submitted automatically on occurrence of event, all other values on a regular basis
- Data collection of status values, settings, as well as alarm and event logs
- Easy to configure and connect.

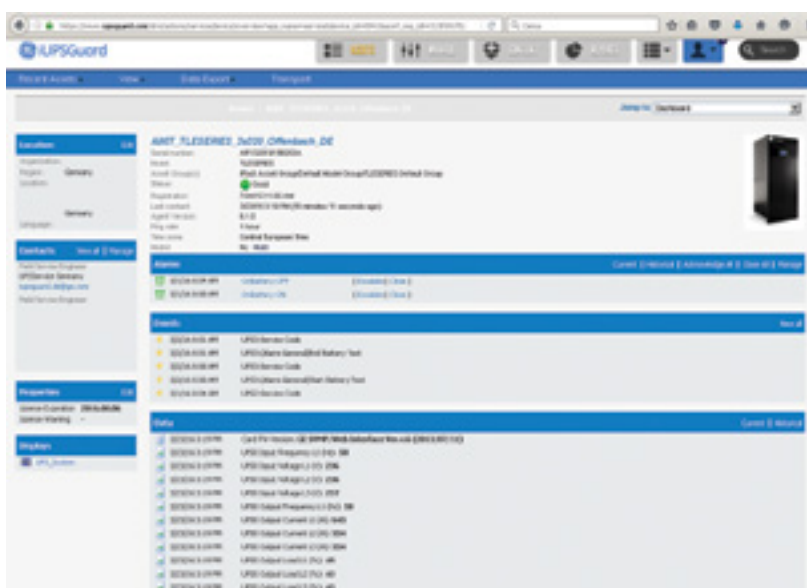

UPS status summary on iUPSGuard

## UPS Monitoring Report

UPS Name: 001\_0010\_00\_0000\_A\_0000\_00  
 UPS Model: 3CDevice  
 UPS SN: 000000000000  
 UPS Type: RTA\_System  
 Quantity of UPS: 2  
 UPS System Rating: 120KVA  
 UPS Software Version:  
 Report Date: September 18 2014

### Load Current (A)

Graph below represents the load variation during the monitoring period

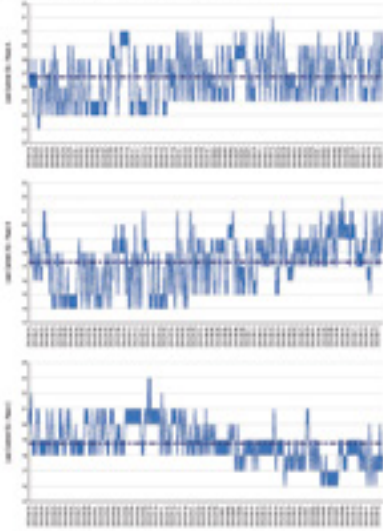

### Input Voltage - UPS Mains

Graph below represents the input voltage variation during the monitoring period

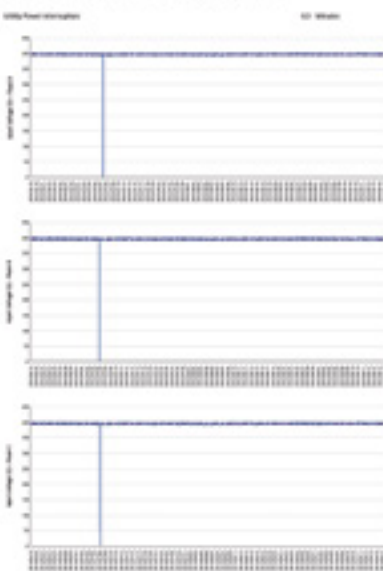

### UPS Operation Mode & Events

System Up Time Information  
 System total operating time (hrs): 430  
 System inactive operating time (hrs): 170  
 System reboot operating time (hrs): 0

Unplanned Load Events  
 For all unplanned load events, record the date, time, and duration of the event.

Event Log Events  
 For all events that occurred during the monitoring period.

Temperature Events  
 For all temperature events that occurred during the monitoring period.

Battery Events  
 For all battery events that occurred during the monitoring period.

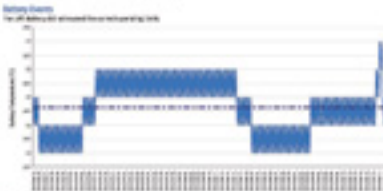

Battery voltage (V)  
 Actual battery voltage problem (V) status

Communication Failure

Asset Communication Loss: 0

Communication Statistics

Web: 7

SNMP: 0

Note:  
 1. In case of UPS System, the serial number mentioned will represent UPS SYSTEM information  
 2. If required, please refer the UPS operating manual for detailed description.

## Key Benefits

### Improved Response Time and High Availability

- 24x7 monitoring of UPS status and operating parameters
- Provides instant alerts in case of critical alarms and events available over web that allows immediate fault analysis as well as corrective actions
- Availability of detailed UPS status improves pre-dispatch diagnostic and first time fix as the service team is arriving pre-informed
- iUPSGuard provides early warning of parameters, operating conditions and diagnostic information that allows resolution of operating anomalies

### Regular UPS Status Reports

- Detailed reporting system of iUPSGuard provides valuable information on equipment operating conditions and trends over period of time
- Summary of events that have occurred and their frequency and duration for the entire monitoring period
- Preparing maintenance recommendation based on data analysis

### Flexible and Scalable

- iUPSGuard can communicate through various channels and monitors single UPS or parallel UPS systems through web/SNMP card

### OS and Android APP Available

- Your assets at a fingertip
- Check alarm, events, measurement on the go
- Intuitive, easy to use user interface

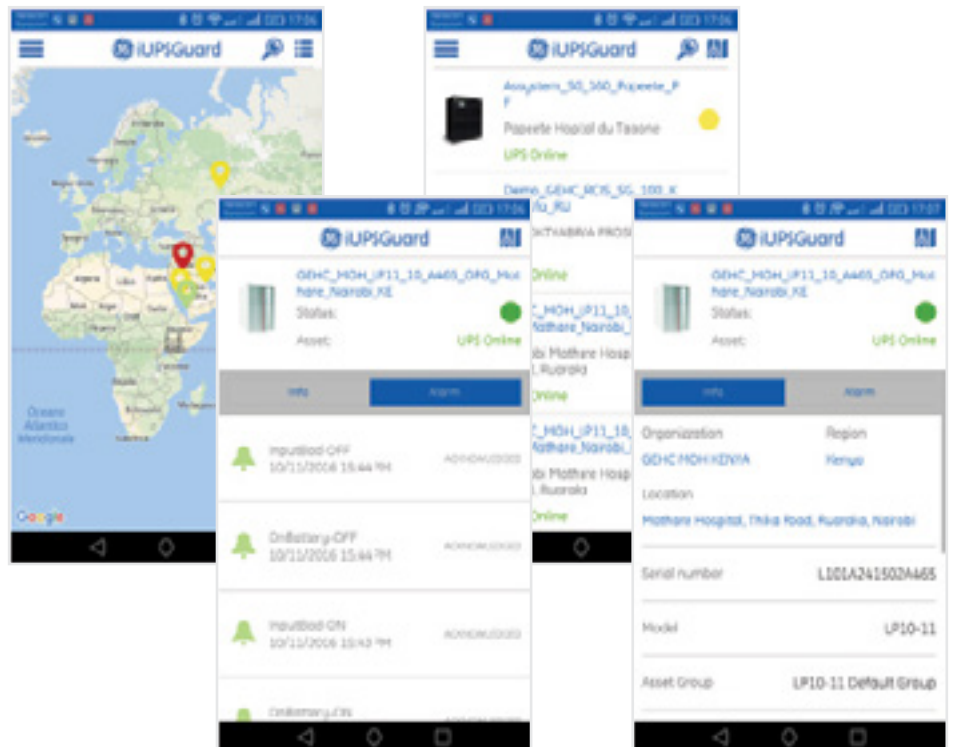

## GE UPS Watch Distributed Architecture & Licensing Options

The GE UPS Monitoring Software helps to ensure the availability and performance levels from the UPS infrastructure. The software helps to manage and supervise UPS networks through the SNMP communication. In addition, network configuration management, layer 2 and 3 discovery, come together in one package that is quick to deploy and tailor to your environment.

### Software Functionalities

- Local Network Monitoring System
- UPS alarms & status changes detected on the spot
- Real-time monitoring & record of UPS measures
- 60s data samples and polling cycles
- Performance monitors & actions on thresholds
- Monitoring GE and third-party UPS via SNMP
- Email & SMS notifications
- Alarm notification based on measures threshold
- Scalable Application server and storage
- Failover functionality for redundant architecture
- Stop notifications from UPS under maintenance
- SNMP MIB compiler facilitates import and management
- Graphical interface available in local languages

## Key Capabilities

### Discovery

Automatically discover UPS and map their connectivity. Build an accurate picture of the network devices and their interconnections, using layer 2 and 3 network technologies. Easily schedule network discoveries or run them on-demand.

### Mapping

Automatically generate a complete layer 2/3 topology map of your UPS network with visibility into both physical and IP connectivity. Easily customize your maps and drill down into UPS performance statistics.

### Monitoring

Using a combination of both active, passive and performance monitoring technologies monitor the health, availability and status of your UPS. Stay ahead of potential performance issues with early warning notifications.

## Advantages

### Unified Dashboard for End-to-End Monitoring

Quickly diagnose and resolve UPS performance issues with easy-to-customize, comprehensive dashboards that enhance monitoring user experience.

## UPS Monitoring - Distributed Edition

In Distributed edition, each Local UPS Monitoring server (also known as remote site) works independently of others: it monitors the UPS of its own facility and send relevant notifications, etc.

In addition the local remote monitoring sends summary status and performance information to the Central server, allowing the administrator to keep the entire network under control from the central site.

This is a highly efficient distributed architecture, since monitoring activities and load are carried out locally and independently at each remote site, reducing central site overhead.



# Distributed Architecture & Licensing Options

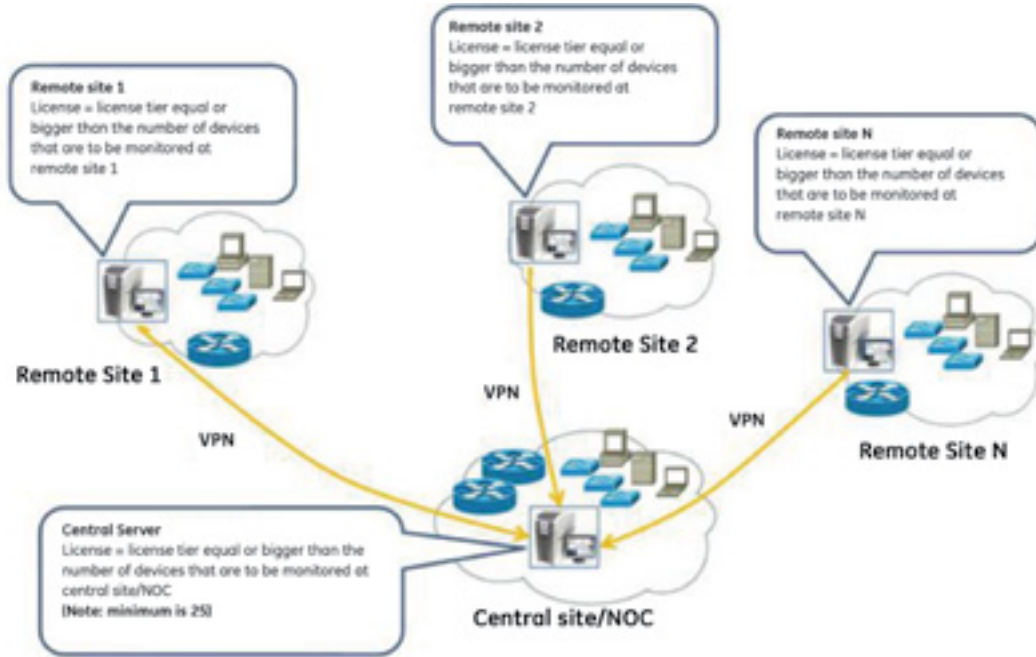

From the central server, aggregated status reports or Top/Threshold performance reports can be generated to poll data from the remote local servers.

Remote sites status summary reports:

Remote Site List	Device Status (Remote)	Monitor Status (Remote)																																																																																																								
<table border="1"> <thead> <tr> <th>Display Name</th> <th>Last Device</th> <th>Last Connected Time</th> <th>Last Snapshot</th> </tr> </thead> <tbody> <tr> <td>WUGDemo02</td> <td>WUGDemo02</td> <td>Tue 06:16 12:05 PM</td> <td>PI 0817 10:34 AM</td> </tr> <tr> <td>WUGDemo01</td> <td>(None)</td> <td>PI 0121 8:40 PM</td> <td>PI 0121 8:40 PM</td> </tr> <tr> <td>WUGDemo01</td> <td>WUGDemo01</td> <td>Sat 06:04 5:31 AM</td> <td>Sat 06:04 5:34 AM</td> </tr> <tr> <td>WUGDemo02</td> <td>WUGDemo02</td> <td>Wed 03:01 1:03 PM</td> <td>PI 0419 1:14 PM</td> </tr> <tr> <td>WUGDemo02</td> <td>(None)</td> <td>Wed 01:05 1:03 PM</td> <td>WUG 0108 1:44 PM</td> </tr> <tr> <td>WUGDemo02</td> <td>WUGDemo02</td> <td>Mon 01:04 1:02 PM</td> <td>WUG 0302 1:07 PM</td> </tr> <tr> <td>WUGSALES</td> <td>WUGSALES</td> <td>Mon 06:07 10:23 AM</td> <td>Tue 08:23 11:43 AM</td> </tr> </tbody> </table>	Display Name	Last Device	Last Connected Time	Last Snapshot	WUGDemo02	WUGDemo02	Tue 06:16 12:05 PM	PI 0817 10:34 AM	WUGDemo01	(None)	PI 0121 8:40 PM	PI 0121 8:40 PM	WUGDemo01	WUGDemo01	Sat 06:04 5:31 AM	Sat 06:04 5:34 AM	WUGDemo02	WUGDemo02	Wed 03:01 1:03 PM	PI 0419 1:14 PM	WUGDemo02	(None)	Wed 01:05 1:03 PM	WUG 0108 1:44 PM	WUGDemo02	WUGDemo02	Mon 01:04 1:02 PM	WUG 0302 1:07 PM	WUGSALES	WUGSALES	Mon 06:07 10:23 AM	Tue 08:23 11:43 AM	<table border="1"> <thead> <tr> <th>Display Name</th> <th>Devices Up</th> <th>Devices Down</th> <th>In Maintenance</th> <th>Last Snapshot</th> </tr> </thead> <tbody> <tr> <td>WUGDemo02</td> <td>1</td> <td>0</td> <td>0</td> <td>PI 0817 10:34 AM</td> </tr> <tr> <td>WUGDemo01</td> <td>36</td> <td>2</td> <td>0</td> <td>PI 0121 8:40 PM</td> </tr> <tr> <td>WUGDemo01</td> <td>246</td> <td>60</td> <td>1</td> <td>Sat 06:04 5:34 AM</td> </tr> <tr> <td>WUGDemo02</td> <td>0</td> <td>0</td> <td>261</td> <td>PI 0419 1:14 PM</td> </tr> <tr> <td>WUGDemo02</td> <td>33</td> <td>18</td> <td>0</td> <td>WUG 0108 1:44 PM</td> </tr> <tr> <td>WUGDemo02</td> <td>33</td> <td>15</td> <td>0</td> <td>WUG 0302 1:07 PM</td> </tr> <tr> <td>WUGSALES</td> <td>43</td> <td>9</td> <td>1</td> <td>Tue 08:23 11:43 AM</td> </tr> </tbody> </table>	Display Name	Devices Up	Devices Down	In Maintenance	Last Snapshot	WUGDemo02	1	0	0	PI 0817 10:34 AM	WUGDemo01	36	2	0	PI 0121 8:40 PM	WUGDemo01	246	60	1	Sat 06:04 5:34 AM	WUGDemo02	0	0	261	PI 0419 1:14 PM	WUGDemo02	33	18	0	WUG 0108 1:44 PM	WUGDemo02	33	15	0	WUG 0302 1:07 PM	WUGSALES	43	9	1	Tue 08:23 11:43 AM	<table border="1"> <thead> <tr> <th>Display Name</th> <th>Monitors Up</th> <th>Monitors Down</th> <th>Last Snapshot</th> </tr> </thead> <tbody> <tr> <td>WUGDemo02</td> <td>1</td> <td>0</td> <td>PI 0817 10:34 AM</td> </tr> <tr> <td>WUGDemo01</td> <td>76</td> <td>3</td> <td>PI 0121 8:40 PM</td> </tr> <tr> <td>WUGDemo01</td> <td>603</td> <td>264</td> <td>Sat 06:04 5:34 AM</td> </tr> <tr> <td>WUGDemo02</td> <td>7</td> <td>4</td> <td>PI 0419 1:14 PM</td> </tr> <tr> <td>WUGDemo02</td> <td>122</td> <td>76</td> <td>WUG 0108 1:44 PM</td> </tr> <tr> <td>WUGDemo02</td> <td>128</td> <td>56</td> <td>WUG 0302 1:07 PM</td> </tr> <tr> <td>WUGSALES</td> <td>150</td> <td>24</td> <td>Tue 08:23 11:43 AM</td> </tr> </tbody> </table>	Display Name	Monitors Up	Monitors Down	Last Snapshot	WUGDemo02	1	0	PI 0817 10:34 AM	WUGDemo01	76	3	PI 0121 8:40 PM	WUGDemo01	603	264	Sat 06:04 5:34 AM	WUGDemo02	7	4	PI 0419 1:14 PM	WUGDemo02	122	76	WUG 0108 1:44 PM	WUGDemo02	128	56	WUG 0302 1:07 PM	WUGSALES	150	24	Tue 08:23 11:43 AM
Display Name	Last Device	Last Connected Time	Last Snapshot																																																																																																							
WUGDemo02	WUGDemo02	Tue 06:16 12:05 PM	PI 0817 10:34 AM																																																																																																							
WUGDemo01	(None)	PI 0121 8:40 PM	PI 0121 8:40 PM																																																																																																							
WUGDemo01	WUGDemo01	Sat 06:04 5:31 AM	Sat 06:04 5:34 AM																																																																																																							
WUGDemo02	WUGDemo02	Wed 03:01 1:03 PM	PI 0419 1:14 PM																																																																																																							
WUGDemo02	(None)	Wed 01:05 1:03 PM	WUG 0108 1:44 PM																																																																																																							
WUGDemo02	WUGDemo02	Mon 01:04 1:02 PM	WUG 0302 1:07 PM																																																																																																							
WUGSALES	WUGSALES	Mon 06:07 10:23 AM	Tue 08:23 11:43 AM																																																																																																							
Display Name	Devices Up	Devices Down	In Maintenance	Last Snapshot																																																																																																						
WUGDemo02	1	0	0	PI 0817 10:34 AM																																																																																																						
WUGDemo01	36	2	0	PI 0121 8:40 PM																																																																																																						
WUGDemo01	246	60	1	Sat 06:04 5:34 AM																																																																																																						
WUGDemo02	0	0	261	PI 0419 1:14 PM																																																																																																						
WUGDemo02	33	18	0	WUG 0108 1:44 PM																																																																																																						
WUGDemo02	33	15	0	WUG 0302 1:07 PM																																																																																																						
WUGSALES	43	9	1	Tue 08:23 11:43 AM																																																																																																						
Display Name	Monitors Up	Monitors Down	Last Snapshot																																																																																																							
WUGDemo02	1	0	PI 0817 10:34 AM																																																																																																							
WUGDemo01	76	3	PI 0121 8:40 PM																																																																																																							
WUGDemo01	603	264	Sat 06:04 5:34 AM																																																																																																							
WUGDemo02	7	4	PI 0419 1:14 PM																																																																																																							
WUGDemo02	122	76	WUG 0108 1:44 PM																																																																																																							
WUGDemo02	128	56	WUG 0302 1:07 PM																																																																																																							
WUGSALES	150	24	Tue 08:23 11:43 AM																																																																																																							
<b>Remote Site Overview</b> <b>WUGSALES</b> http address: http://wugsales Last connected time: Tuesday, June 27, 2011 10:23:36 AM Last snapshot: Tuesday, June 28, 2011 10:12:43 AM # of devices: 83 # of monitors: 270 # of queries: 43	<b>Remote Site Overview</b> <b>WugDemo01</b> http address: http://wugdemo01-01 Last connected time: Saturday, June 24, 2011 08:33:07 AM Last snapshot: Saturday, June 24, 2011 08:34:08 AM # of devices: 309 # of monitors: 183 # of queries: 120	<b>Remote Site Overview</b> <b>WugDemo02</b> http address: http://wugdemo02 Last connected time: Wednesday, April 13, 2011 01:03:23 PM Last snapshot: Friday, April 15, 2011 02:14:42 PM # of devices: 261 # of monitors: 308 # of queries: 15																																																																																																								
<b>Summary Counts (Remote)</b> <b>WUGSALES</b> Count: Total number of 66 Monitors Devices 43 Up Devices 9 Down Devices 7 Devices with Down Active Monitors 1 Devices in Maintenance 246 Disabled Active Monitors 109 Up Active Monitors 64 Down Active Monitors 100 Up/No Tools 71 Down Interfaces 267 Unacknowledged Devices 8 Active Time in the last 1 Hour	<b>Summary Counts (Remote)</b> <b>WugDemo01</b> Count: Total number of 309 Monitors Devices 236 Up Devices 61 Down Devices 26 Devices with Down Active Monitors 3 Devices in Maintenance 244 Disabled Active Monitors 602 Up Active Monitors 64 Down Active Monitors 540 Up/No Tools 60 Down Interfaces 267 Unacknowledged Devices 8 Active Time in the last 1 Hour	<b>Active Monitor States (Remote)</b> <b>WugDemo01</b> Monitor type: All active monitor types Monitor state: Up 172.16.42.107 172.16.42.118 172.16.42.144 172.16.42.186 172.16.42.14 172.16.42.23 172.16.42.33 172.16.42.4 172.16.42.0 172.16.42.33 192.168.254.11 Monitor state: Up Monitor state: Down Monitor state: Disabled Monitor state: Unack																																																																																																								
<b>Active Monitor States (Remote)</b> <b>WUGSALES</b> Monitor type: All active monitor types Monitor state: Up 10.0.1.45 10.0.25 10.0.26 10.0.27	<b>Active Monitor States (Remote)</b> <b>WugDemo02</b> Monitor type: All active monitor types Monitor state: Down 10.0.1.8 10.0.10 10.0.12 10.0.14 10.0.16	<b>Active Monitor States (Remote)</b> <b>WugDemo01</b> Monitor type: All active monitor types Monitor state: Up 172.16.42.107 172.16.42.118 172.16.42.144 172.16.42.186 172.16.42.14 172.16.42.23 172.16.42.33 172.16.42.4 172.16.42.0 172.16.42.33 192.168.254.11 Monitor state: Up Monitor state: Down Monitor state: Disabled Monitor state: Unack																																																																																																								

# Transfer Switches

## STS Series - Static Transfer Switches

230V / 3x400V 16-1600A 2/3/4-pole



### Function

Providing high-reliability power protection for IT servers/storage/network equipment and other digital electronics

### Typical Applications

- Data centers
- Manufacturing and process control units
- Broadcast and satellite transmission systems
- Emergency lighting systems
- Security systems
- Financial systems and services



### Standards & Certification

IEC 62310-1:2005 (safety)

IEC 62310-2:2006 (EMC)

### Overview

Static Transfer Switches (STS) are designed to transfer the supply between two independent AC power sources. Unlike traditional automatic transfer switches (ATS), a static transfer switch provides a fast load transfer (typically 1/4 of a cycle), which ensures uninterrupted operation of sensitive electronic equipment. Load retransfer to the preferred input source is virtually instantaneous (typically 0.2 ms). The basic applications of STS are in automatic systems in the power industry, power supply systems for petrochemical industry, computer and telecommunication centres, automatic and security systems of 'intelligent' buildings as well as other equipment which is sensitive to interruptions in the supply. The excellent overload capability and transfer algorithm enables fast fuse clearance in the event of a short-circuit. As a consequence the voltage immediately returns to normal to supply the other loads. The built-in transient voltage surge suppression system for SCR switches provides additional protection against damage to the supplied equipment.

The static transfer switch consists of two bidirectional thyristor switches for each phase equipped with a control and protection system. The 2 or 4-pole types have an additional neutral line switch. After failure of the preferred source, the STS checks the state of the alternate power source and transfers the load to whichever source provides power within selectable limits. This transfer can be triggered by disturbance in the preferred source voltage, overcurrent in the source or manual or remote change of the preferred source. With both sources in limits and synchronised (phase error within the acceptable range), manual or remote transfer is performed in less than 200  $\mu$ s. Transfers initiated by fault conditions in the preferred source depend on the status of the alternate source. For synchronised power sources with phase error within the limits, transfer to an alternate source is made within 5ms delay. Lack of synchronisation causes delay before transfer. It is possible to set the delay with dipswitches.

Through their complete life cycle, all GE's systems are fully supported by service teams which provide world-class, 24x7 preventive and corrective services, training and application expertise.

### Features and Benefits

- Selectable voltage limits for full flexibility to protect equipment against sags, swells and interruptions
- Three redundant power supplies providing maximum reliability
- Fail-safe high noise immunity CMOS logic for fast and reliable control of the STS
- Easy to install and to operate
- Redundant cooling providing full functionality, even in case of a fan failure
- Surge protection to prevent damage to the STS and the supplied equipment
- Blocked transfer in case of short circuit preventing jeopardy to other users
- Manual bypass for no-break operation of the load during maintenance
- Dry contacts to provide status and alarm information to other control systems
- Rackmounted models for easy integration into other systems
- User friendly control panel for easy operation
- Neutral wires are sized for 200% of nominal current to handle unbalanced loads

# Specifications

NOMINAL CURRENT RATING (A)	16	25	32	40	63	100	150	250	400	630	800	1000	1250	1600	
<b>Enclosures</b>															
2-pole, 19 inch rackmount	G				-										
3-pole, floorstanding cabinet	-			A			B			C		D		E	
4-pole, floorstanding cabinet	-			A			B			C		D		E	
3-pole, 19 inch rackmount	F				-										
4-pole, 19 inch rackmount	F				-										
Weight (kg), only for 3 and 4-pole floor standing cabinet				150kg	170kg		220kg	240kg	280kg	350kg		500kg	620kg	680kg	
Colour	RAL 9005														
<b>Input characteristics</b>															
Nominal input voltage	400V ph-ph / 230V ph-N														
Input voltage window	-25% +25%														
Nominal frequency	50Hz / 60Hz (on request)														
Frequency window	-10 / +10%														
<b>Output characteristics</b>															
Efficiency	> 99% at cos phi > 0.8														
Crest factor acceptance	3.5:1														
Power factor (max. Cos phi)	0.5 - 1.0 (leading/lagging)														
Overload behaviour	125%:1 hour / 400%:5 s / 800%:0,4 s / 1000%:0,2 s / 1500%:20 ms														
Short circuit fuse current withstand, kA	50							75							
Transfer time (manual triggering)	≤ 13 ms														
<b>Settings</b>															
Overvoltage level setting	+6/9/12/16/20/24% selectable by dipswitch														
Undervoltage level setting	-6/9/12/16/20/24%														
Phase delay limit (for synchronised sources)	6/10/15 degrees, selectable by dipswitch														
Transfer blocked after output current exceeding limit	No blocking, 3/4.5/6/7.5/9xnominal current, selectable by dipswitch														
Transfer time (sources not synchronised)	11/15/22/50ms, selectable by dipswitch														
Delay for retransfer to preferred source	0.8/1/5s selectable by dipswitch														
<b>Ambient conditions</b>															
Operating temperature	0 - 40 °C														
Humidity	< 95%, non-condensing														
Altitude	1000 m (above 1000 m 5% derating per 500 m; max. 3000 m)														
Cooling	Redundant cooling fans														
Audible noise	55-62dB(A)														
EMC	IEC 62310-2														
Protection	IP 20 (floorstanding), IP 00 (for rackmounted models)														
<b>Alarm / Status Contacts</b>															
Dry contacts	125Vdc or 250Vax/ 0.3Adc or 4Aac at 220V														
Status information	Manual transfer on, retransfer off, primary/secondary source OK, primary/secondary source on														
Disturbance alarms	Primary/secondary source not healthy, sources not synchronized														
Failure alarms	overcurrent, overtemperature, TVSS failure, fuse failure, internal STS failure														

**Enclosures (WxDxH, mm):** A: 680\*660\*1400 B: 860\*860\*1800 C: 660\*1060\*1800 D: 860\*1860\*1800 E: 860\*2060\*1800 F: 483\*400\*267  
G: 483x400x133 \*Optional Manual Bypass (483x215x133)

# GTX Series - Automatic Transfer Switches

## Emergency Standby ATS



### Function

Power contactor switch for emergency standby applications.

### Typical Applications

- Light industrial and commercial critical applications



### Standards & Certification

IEC60947-6-1: 2013 revision  
GB14048.11-2008 revision

### Overview

GTX Series - Standard (Open transition) IEC Certified

The Zenith GTX Series of automatic transfer switches (ATS) are built for light industrial and commercial critical applications requiring the dependability and ease of operation found in a power contactor switch. The GTX transfer switches are designed for standby applications, and incorporate a double-throw, mechanically interlocked contactor mechanism.

The GTX transfer switches are equipped with an optional **MX70 Microprocessor Control Panel**.

### Features and Benefits

- Undervoltage sensing (90% pickup/80% dropout) of the utility source
- Voltage and frequency sensing of the generator source (90% voltage/95% frequency pickup)
- Time Delay Engine Start - 3 seconds (P)
- Time Delay Engine Warmup - Transfer to Generator - 3 seconds (W)
- Time Delay Utility Stabilization/Retransfer to Utility - 10 minutes (T)
- Time Delay Engine Cool Down - 5 minutes (U)
- Indicating LEDs for power availability, switch position and load energized
- Pushbuttons for test, engine start (manual), generator exerciser, timer bypass and program cancel
- Wiring interconnection plug designed to prevent mis-operation errors
- Special status annunciation of in-phase transfer and timer operation
- Smart diagnosis program and in phase monitor
- Selectable 7, 14, 21 or 28 day (factory set 28 days) generator exerciser timer
- Diagnostic LED indications in logical one-line configuration. All time delays can be adjusted using MX70 software.

### The GTX Power Panel Includes:

- Double throw and mechanically held
- Arc quenching grids, enclosed arc chamber and wide contact air gap
- Fast contact transfer speed less than 100ms

The unit is available in open type (non-enclosure), NEMA 1 (IP20) or NEMA 3R (IP24) enclosures. Additional options include:

- A3/A4 Auxiliary contacts (1 each) closed in Source 1 and Source 2 positions

### Options

- Ratings 40 to 400 amps
- IEC 60947-6:2013 Certified, Class PC
- 2, 3, and 4-pole
- Power contactor ATS
- 120-416Vac rated voltage
- 50/60 Hz rated frequency

# ZTG Series - General Purpose ATS



## Function

Power contactor transfer switch for applications requiring dependability and ease of operation.

## Typical Applications

- General purpose commercial and industrial applications



## Standards & Certification

Safety: EN 62040-1/A1 (EN 62050-1)

EMC: EN 62040-2

## Overview

### ZTG Series - Standard (Open) or Delayed Transition

The Zenith ZTG Series of transfer switches are built for general purpose commercial and industrial applications requiring the dependability and ease of operation found in a power contactor switch. The ZTG series uses the MX150 microprocessor control system, which includes features specified on a general purpose commercial and industrial applications. It also provides an intuitive user interface, communications capability and self diagnostics. The ZTG Series is available in a full range of ampere, voltage and pole configurations, along with many commonly requested options and features.

## Features and Benefits

- Close differential under-voltage sensing of the normal source
- Voltage and frequency sensing of the emergency source
- Test switch (fast test/load/no load) to simulate normal source failure - automatically bypassed should the emergency source fail
- Double throw, interlocked operation
- Electrically operated, mechanically held by a simple, over-center mechanism
- Segmented silver tungsten alloy contacts with separate arcing contacts on 600 amps and above
- Arc quenching grids, enclosed arc chambers and wide contact air gap for superior source-to-source isolation on all units
- Control circuit disconnect plug and drive inhibit switch for safe maintenance
- Components accessible for inspection and maintenance without removal of the switch or the power conductors
- Mechanical indicator and contact chamber cover designed for inspection, safety and position designation
- Offering a Warranty Period of twenty-four (24) months or two years from the date of shipment

## Applicable Specifications

- Durable, long-life solenoid operated mechanism
- GE-engineered and manufactured contacts and arc quenching components
- OSHPD seismic qualifications

## Configurations

### • ZTG - Standard (Open) Transition

The Zenith ZTG transfer switch is used in general and mixed load applications.

### • ZTGD - Delayed Transition

The Zenith ZTGD transfer switch is used for the transfer of large motor or inductive loads.

## Options

- Ratings 40 to 3000 amperes
- 120 - 600 Volts
- 50 or 60 Hz
- 2, 3 or 4-pole
- Double throw, mechanically interlocked contactor mechanism
- Suitable for emergency and standby applications
- Open type, NEMA 1, 3R, 4, 4X and 12 enclosures

# ZTS Series - Business Critical and Industrial Applications



## Function

Power contactor based transfer switch for applications requiring reliability and enhanced operational features.

## Typical Applications

- Business and Industrial critical applications.



## Standards & Certification

UL 1008 listed at 480 VAC

UL1008 7th Edition Standard

CSA C22.2 No.178 certified at 600 VAC

Seismic certified to IEEE-693-2005 at High Level with 2.5 amplification factor

Seismic certified to OSHPD using testing standard ICC-ES-AC-156

ISO 9001 certified manufacturing plant

UL-3 cycle ( unconditional) short circuit withstand & close ratings

OSHPD seismic qualifications

## Overview

### ZTS Series - Standard (Open), Delayed or Closed Transition

The Zenith ZTS Series of automatic transfer switches (ATS) are built for business and industrial critical applications requiring the reliability and enhanced operation. The ZTS Series uses the MX250 microprocessor control system, which includes features specified for use in business and industrial critical applications. It also provides an intuitive user interface, communications capability and self diagnostics.

The ZTS Series is available in a full range of ampere, voltage and pole configurations, along with an extensive list of options and features.

## Features and Benefits

- Contact transfer speed less than 100 milliseconds
- High close-in and withstand capability
- Double throw, interlocked operation
- Electrically operated, mechanically held by a simple, over-center mechanism
- Segmented silver tungsten alloy contacts with separate arcing contacts on 600 amps and above
- Arc quenching grids, enclosed arc chambers and wide contact air gap for superior source-to-source isolation on all units
- Control circuit disconnect plug and drive inhibit switch for safe maintenance
- Components accessible for inspection and maintenance without removal of the switch or the power conductors
- Mechanical indicator and contact chamber cover designed for inspection, safety and position designation

## Configurations

### • ZTS - Standard (Open) Transition

The Zenith ZTS transfer switch is used in general and mixed load applications.

### • ZTSD - Delayed Transition

The Zenith ZTSD transfer switch is used to transfer of motor loads, and transformers.

### • ZTSCT - Closed Transition

The Zenith ZTSCT transfer switch is used to transfer critical loads where a “no break” transfer is desired with this switch 100msec parallel capability.

### • ZBTS Series, Bypass

The ZBTS bypass transfer switch is available in all 3 transition types (standard, delayed, and closed transition). The ZBTS provides all the features and benefits of the ZTS series ATS with the added ability to disengage and rack out the ATS all the while maintaining power to your critical load via a built in manually operated bypass panel.

## Applicable Specifications

- Temperature rise test per UL 1008 conducted after overload and endurance tests in unventilated enclosure-exceeds UL requirements
- UL 1008 listed at 480 VAC
- UL 3-cycle (unconditional) short circuit withstand & close ratings
- OSHPD seismic qualifications

## Options

- Ratings 40 to 4000 amperes
- 120 - 600 Volts
- 2, 3 or 4-pole
- Open type, NEMA 1, 3R, 4, 4X and 12 enclosures
- 120 to 600 VAC, 50 or 60 Hz
- Suitable for emergency and standby applications on all classes of load, 100% tungsten rated through 400 amps
- Available in ZTS (utility-generator), ZTSU (utility-utility), ZTSG (generator-generator) and ZTSM (manual) configurations

## ZBTS - Bypass/Isolation

The Zenith ZBTS Series of Bypass/Isolation automatic transfer switches (ATS) are built for business and industrial critical applications requiring the reliability and enhanced operation. The ZBTS Series uses the MX250 microprocessor control system, which includes features specified for use in business and industrial critical applications. It also provides an intuitive user interface, communications capability and self diagnostics. In business and industrial critical applications power cannot be interrupted to perform maintenance of automatic transfer switches. In such circumstances, a bypass/isolation switch is essential and is often required by code.

Zenith ZBTS Series Bypass-Isolation Transfer Switches are the solution when interruption of power during service or testing is not acceptable. Consisting of two major modules - the Automatic Transfer (ATS) and the Bypass/Isolation Switch. The ZBTS Series incorporates the rugged construction of all our ZTS Series automatic switches with a quick make/quick break bypass switch manual load transfer handle and our control/interlock system, which consists of both mechanical and electrical interlocks.

The bypass uses normal failure sensing and a time delay to start the engine automatically if a failure occurs when the ATS has been removed for service - which can be done without disturbing the load.

## Features and Benefits

- Load is not interrupted during bypass & isolation operation
- High close-in and withstand capacity
- Automatic transfer switch is located on a draw-out mechanism to facilitate maintenance
- Emergency power systems can be electrically tested without disturbing the load
- Power cables do not have to be disconnected to remove automatic transfer switch
- Bypass to any available source with ATS removed
- Engine start circuit maintained during bypass operation; normal power failure causes engine start contact closure even with the ATS removed
- Diagnostic lights and detailed instructions for simple step-by-step operation
- Mechanical and electrical interlocks ensure proper sequence of operation
- Bypass switch contacts are closed only during the bypass-isolation operation
- Silverplated copper bus interconnection of the transfer and bypass switches on all sizes

## Configurations

### • ZBTS - Bypass/Isolation

The Zenith ZBTS Bypass/Isolation transfer switch is used in general and mixed load applications.

### • ZBTSD - Delayed Transition Bypass/Isolation

The Zenith ZBTSD Bypass/Isolation transfer switch is used to transfer of large motor loads, transformers, uninterruptible power supplies (UPS) systems or load shedding to a neutral "center" position.

### • ZBTSCT - Closed Transition Bypass/Isolation

The Zenith ZBTSCT Bypass/Isolation transfer switch is used to transfer critical loads where a "no break" transfer is desired with this switch 100msec parallel capability.

## Standard & Certification

UL 1008 listed up to 480 VAC

CSA C22.2 No. 178 certified up to 600 VAC

Certified to IEC 60947-6-1 up to 480 VAC

Seismic certified to IEEE-693-2005 at HIGH level with 2.5 amplification factor

Seismic certified to IBC-2009 at  $I_p=1.5$  for  $z/h$  less than or equal to 1

Seismic certified to OSHPD per testing standard ICC-ES AC-156

ISO 9001 certified manufacturing plant

## Options for ZTBS

- Ratings 100 to 4000 amperes
- 2, 3 or 4-pole
- Open type, NEMA 1, 3R, 4, 4X and 12 enclosures
- 120 to 600 VAC, 50 or 60 Hz
- Bypass and automatic transfer switch have identical ratings
- Suitable for emergency and standby applications on all classes of load, 100% tungsten rated through 400 amps
- Available in ZBTS (utility-generator), ZBTSU (utility-utility), ZBTSG (generator-generator) and ZBTSM (manual) configurations

# ZTE Series - Mission, Process, Healthcare Critical



## Function

Power contactor based transfer switch for users that require advanced metering, communication, and data analytics.

## Typical Applications

- Data centers, healthcare facilities, and other mission critical systems.



## Standards & Certification

UL 1008 listed at 480 VAC

UL1008 7th Edition Standard

CSA C22.2 No.178 certified at 600 VAC

Seismic certified to IEEE-693-2005 at High Level with 2.5 amplification factor

Seismic certified to OSHPD using testing standard ICC-ES-AC-156

ISO 9001 certified manufacturing plan

UL-3 cycle ( unconditional) short circuit withstand & close ratings

OSHPD seismic qualifications

## Overview

### ZTE Series - Standard (Open), Delayed or Closed transition

The ZTE Series automatic transfer switch (ATS) is ideal for use in today's 7x24 service centers, data warehouses and critical healthcare facilities. These mission critical sites demand more than just continuity of power, and the ZTE meets these challenges.

Poor power quality damages equipment and increases maintenance costs. Inherent power problems stay hidden when testing is ineffective or incomplete. Going beyond source switching and addressing the issues of complete power quality requires a whole new level of ATS capability. The ZTE Series ATS is ideal for use in this environment.

## Features and Benefits

- Robust Switching Mechanisms
- Ratings 40 to 4000 amperes
- 2, 3 or 4-pole
- Open type, NEMA 1, 3R, 4, 4X and 12 enclosures
- 120 to 600 VAC, 50 or 60 Hz
- Suitable for emergency and standby applications on all classes of load, 100% tungsten rated through 400 amps
- UL 3-cycle (unconditional) short circuit withstand & close ratings
- OSHPD seismic qualifications

## Configurations

### • ZTE Series, Standard (Open) Transition

The GE Zenith ZTE standard (open) transition transfer switches go beyond just source switching. Integral metering and communications, high-level diagnostics and superlative flexibility make the ZTE a perfect solution for today's mission critical source switching.

### • ZTED Series, Delayed Transition

The ZTED - Delayed Transition transfer switch offers the same features as the ZTE with the addition of an adjustable time delay in the centered "off" position. This delay allows motor loads to coast down and transformer field to decay; ensuring inductive loads are re-energized after transfer with only normal inrush starting currents.

### • ZTECT Series, Closed Transition

The ZTEC - Closed Transition transfer switch offers the same features as the ZTE with the addition of a high-speed drive system, which ensures the overlap of the normal and alternate sources is less than 100 milliseconds. When one source is not within normal limits, such as during a power outage, the ZTECT automatically operates in delayed transition mode.

### • ZBTE Series, Bypass

The ZBTE bypass transfer switch is available in all 3 transition types (standard, delayed, and closed transition). The ZBTE provides all the features and benefits of the ZTE series ATS with the added ability to disengage and rack out the ATS all the while maintaining power to your critical load via a built in manually operated bypass panel.

## Advanced User Interface & Controls

- Color graphical display with built-in Help menus
- System status LEDs and menu-driven soft keys
- Dedicated control and navigational pushbuttons
- Front accessible USB programming port
- Password protected control switches



## Built-in Power Quality Metering

- 3-phase current, including neutral, voltage, power, energy, frequency and harmonics (THD)
- 20 Channel Data Logger with sampling rates user-configurable from 1 cycle to 60 minutes

## Enhanced Connectivity

- Built-in RS-485 serial and RJ-45 Ethernet
- Open protocols - Modbus RTU and TCP/IP
- User-configurable data map
- Download of event, waveform, and data log to PC
- Customized control logic using GE FlexLogic
- Local/remote configuration via EnerVista MX350 Setup software
- Plug-and-play PC monitoring and control using EnerVista Viewpoint Monitoring software

## Diagnostics & Event Recording

- Power source anomaly events recorder
- Detailed transfer event reporting
- Local storage of 256 time-stamped events with 1 ms resolution
- User-configurable alarms

## Flexible Feature Assignment

- Field modification of control features
- User-configurable load control contacts
- Reduced commissioning delays from incorrect configuration

## Reliability

- Durable solenoid ATS operated mechanisms and robust electronics, tested for severe EMC and environmental conditions

## Advanced Troubleshooting

- High-speed event log and data logging

## Diagnostics

- Advanced system troubleshooting and event reporting

## Low Cost Installation & Quick Commissioning

- Built-in networking for reduced hardwiring, centrally located customer connections; simple field modification of features without need for factory service

## Flexible & Expandable for Changing Site Needs

- Modular, expandable I/O and field-upgradeable features for maximum flexibility

## Power Quality Metering

- True PQ metering, including waveform, harmonics and high-speed event capture

## Simple & Low-Cost Facility Integration & Monitoring

- Built-in networking, customizable User Data Map, and plug-and-play monitoring using EnerVista Viewpoint Monitoring software





# GE UPS Solutions

## Complementary Matching Switchgear For GE TLE CE UPS, 30-800kVA

### Why use GE-Provided Complementary UPS Switchgear Solutions?

- Designed to meet the size form factor and color of the GE TLE UPS Module
- Designed with proper control circuits to operate properly with the GE TLE UPS Module
- 2-Year Warranty of TLE UPS Module is extended to the matching Switchgear
- Customer desires an integrated UPS System Solution from GE, not just a UPS Module
- Provides Flexible UPS Output Distribution, using GE Industrial Solution components
- Qualified by GE as suitable for use with GE UPS Systems

### Parallel UPS Output RPA Switchgear

- UPS Module Output Isolation CBs
- UPS System Output Isolation & Bypass CBs
- SKRU Electric Interlocks
- Various KAIC Breaker Fault ratings
- Side Cable Access for cabling to UPS Module
- Matching Height, Depth, Color

Lead Time: 4-6 weeks ARO + transit time from Europe-based swgr plant

### UPS Maintenance Bypass Switchgear

- 3-CB Type (UPS Input Iso, Output Iso, Bypass CBs)
- 2-CB Type (Same without UPS Input Iso CB)
- Mechanical or SKRU Electric Interlocks
- Various KAIC Breaker Fault ratings
- Side Cable Access for cabling to UPS Module
- Matching Height, Depth, Color

Lead Time: 2-4 weeks ARO + transit time from Europe-based swgr plants

### UPS Output Distribution Switchgear

- Output Distribution 3ph 4w Panelboard, or
- Output Distribution Subfeed 3-pole CBs
- Front Facing or Side Facing
- Various KAIC Breaker Fault ratings
- Side Cable Access for cabling to UPS Module
- Matching Height, Depth, Color

Lead Time: 2-4 weeks ARO + transit time from Europe-based swgr plants



# UPS Maintenance Bypass Panel

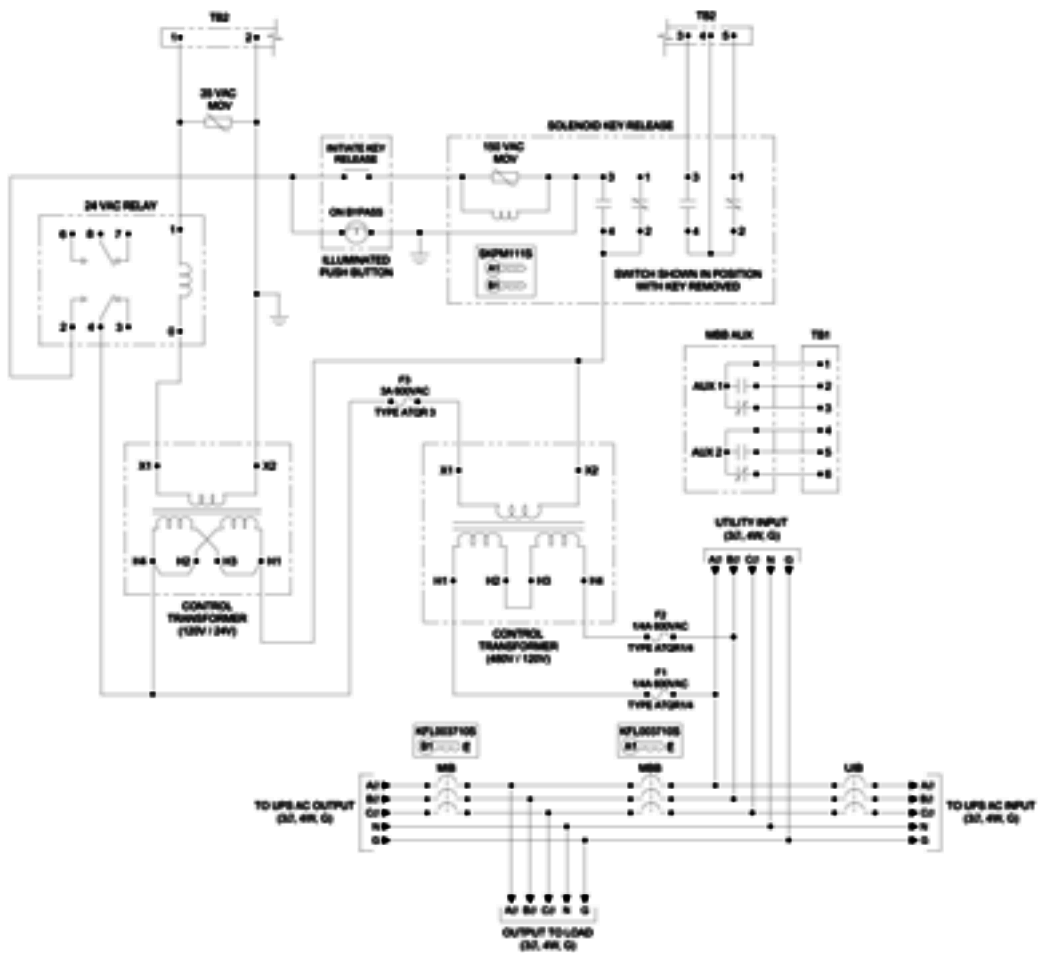
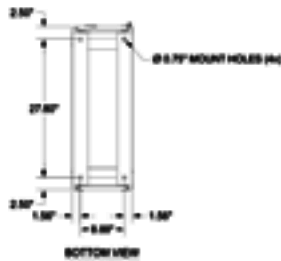
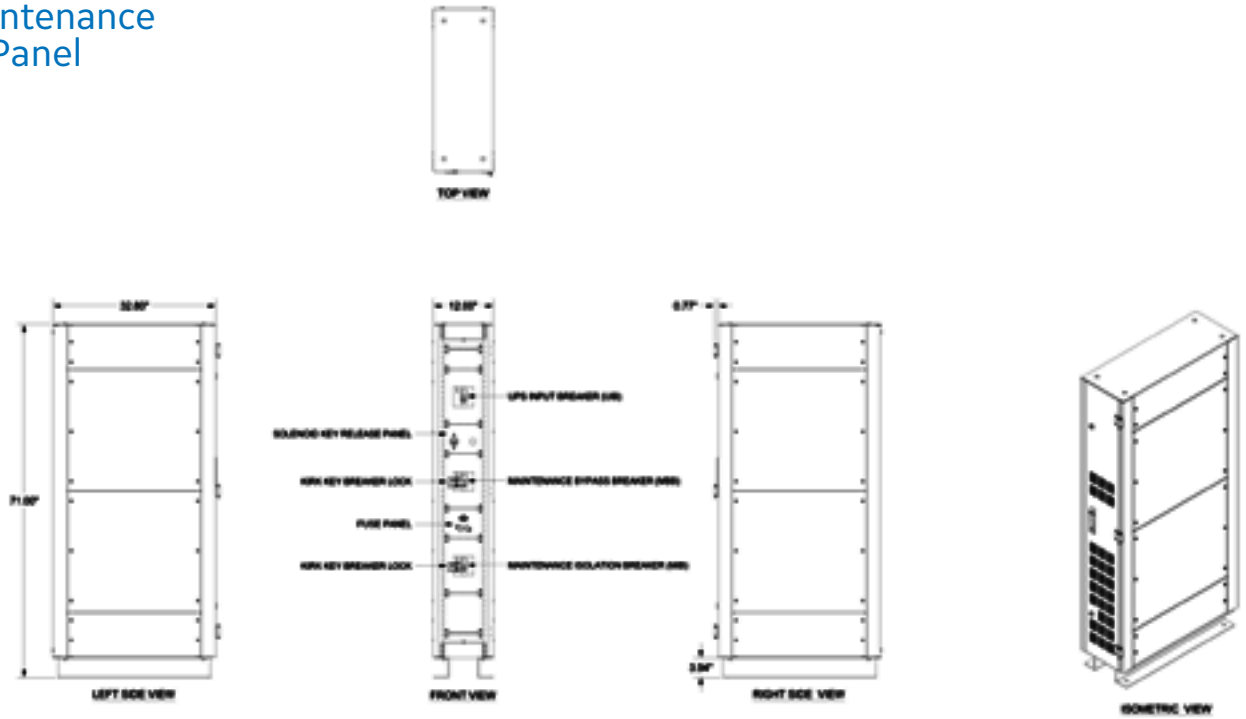

# DC Energy Storage Flywheel

## Green Short-Term Backup Power for GE TLE/SG UPS

### Why use a GE Flywheel UPS Solution?

- 98% of power quality disturbances are less than 10 seconds.
- Modern Backup Generators are complete the power restoration cutover from a lost utility source in less than 10 seconds.
- IT Datacenter Trends making flywheels more attractive:
  - IT Server Virtualization and software redundancy, allowing UPS Systems to have much shorter backup times
  - Datacenter ambient room temperatures on the rise due to server equipment hardening, thus making temperature-sensitive VRLA UPS batteries less practical
  - Proliferation of new GREEN Datacenters, desiring green solutions which do not include toxic VRLA batteries
- Non-IT Critical Processes that find UPS backup times of less than 1 minute acceptable
  - Medical imaging market
  - Broadcast transmitter market
  - Industrial process market
  - Transportation market (Rail, etc)
  - Casino gaming market
- Lead Acid Batteries do not perform correctly with a UPS System when designed backup support times are less than 3 minutes.

	FLYWHEEL	VRLA BATTERY
<b>Maintenance</b>	Annual	Quarterly
<b>HVAC Costs</b>	None	Med-High
<b>Reliability</b>	50,000 hrs+ MTBF	2,200 hrs+ MTBF
<b>Life Expectance</b>	20 years	4-5 years
<b>Installation Cost</b>	Low	Med-High
<b>Hazardous Material</b>	None	Lead & Acid
<b>Toxic Emissions</b>	None	Hydrogen
<b>Diagnostics/Monitoring</b>	Accurate	Speculative
<b>Disposal Requirements</b>	None	Required

### Flywheel Availability:

- With SG UPS
- With TLE UPS

### Leadtime:

- 5-6 weeks ARO + transit time from California USA

Consult GE Application Engineering for Pricing, Quotations, Drawings

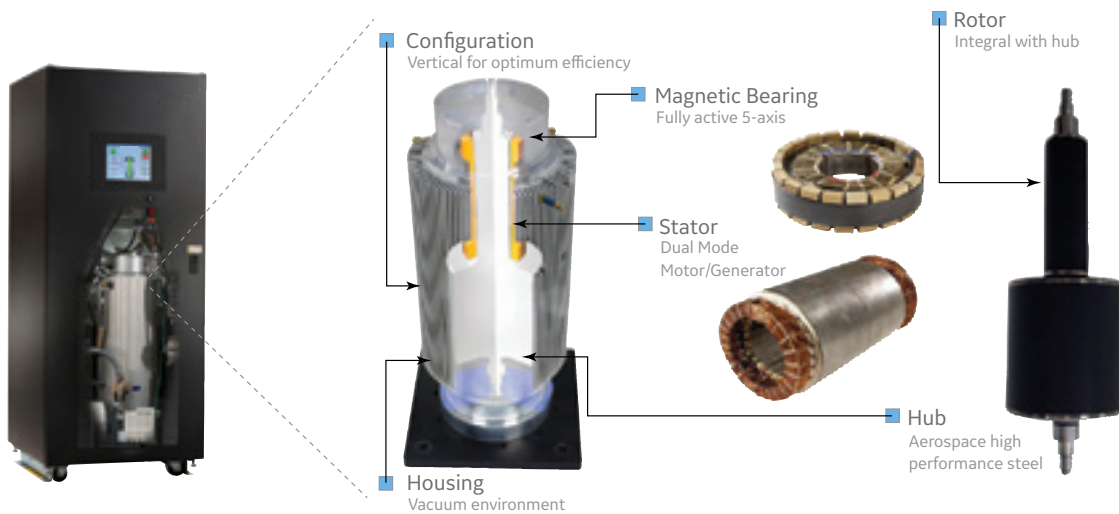

# UPS Output Power Rating (kVA)

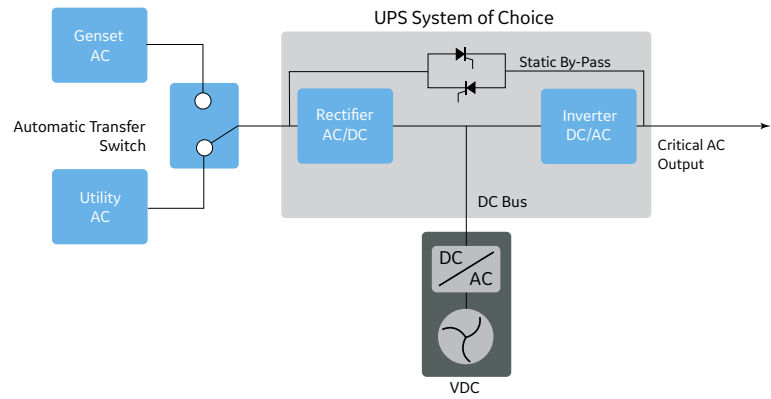

## TLE UPS Applications

### Enhanced Flywheel

GE UPS MODELS	CE TLE 60	CE TLE 80	CE TLE 100	CE TLE 120	CE TLE 160	CE TLE 200	CE TLE 320	CE TLE 400	CE TLE 600	CE TLE 800
kW	60	80	100	120	160	200	320	400	600	800
# of units										
1	94	72	57	45	32	23				
2		140	111	92	71	56	31	22		
3					103	83	51	40	22	13
4							69	55	33	22
5								69	45	30
6									55	39

### Standard Flywheel

GE UPS MODELS	CE TLE 60	CE TLE 80	CE TLE 100	CE TLE 120	CE TLE 160	CE TLE 200	CE TLE 320	CE TLE 400	CE TLE 600	CE TLE 800
kW	60	80	100	120	160	200	320	400	600	800
# of units										
1	59	44	35	29	23	17				
2		87	70	58	46	36	22	16		
3					69	55	33	26	16	10
4							45	35	23	16
5								45	29	21
6									35	26

Run times are rounded off to the nearest second and are based on UPS with 540Vdc float voltage and 96% inverter efficiency

## SG UPS Applications

### Enhanced Flywheel

GE UPS MODELS	CE SG 60	CE SG 80	CE SG 100	CE SG 120	CE SG 160	CE SG 200	CE SG 250	CE SG 300	CE SG 400	CE SG 500
kW	54	72	90	108	128	180	225	270	360	450
# of units										
1	103	79	63	51	35	25	17			
2		155	123	101	77	62	48	38	24	17
3					114	91	74	62	44	32
4							96	80	61	47
5									76	61

### Standard Flywheel

GE UPS MODELS	CE SG 60	CE SG 80	CE SG 100	CE SG 120	CE SG 160	CE SG 200	CE SG 250	CE SG 300	CE SG 400	CE SG 500
kW	54	72	90	108	128	180	225	270	360	450
# of units										
1	65	48	37	32	23	18	14			
2		97	77	64	48	38	30	24	18	13
3					72	57	45	37	27	21
4							60	50	37	29
5									47	37

Run times are rounded off to the nearest second and are based on UPS with 540Vdc float voltage and 96% inverter efficiency

# PowerMOD Modular Container

For Fast Deployment of Efficient, Mission-Critical Power, 200 - 1200 kW

Picture this: you're responsible for flawless operation of urgent or temporary mission-critical processes. You are confronted with an unreliable utility grid, incapable of supplying the clean power your equipment needs. And due to severe time constraints building a new UPS room is not an option, or there is no space at all to build one...

You need a proper solution for these urgent issues, and most of all: you need it FAST. What to do?

## The solution

The GE PowerMOD™ Containerized Power Solution is just what you need: an innovative, high-density, turnkey and energy-efficient mission-critical power system. It delivers continuous and moderated power efficiently and reliably, regardless the quality or availability of grid or generator power. The system is modular, pretested, and ready to use.

## What is it?

The PowerMOD integrated module is an all-in-one power quality protection system, housed in a single container.

The system consists of:

- Uninterruptible Power Supply (UPS) and related batteries
- Power Distribution Units or Busway as needed
- Input/Output switchgear, ATS, transformers as needed
- Auxiliary supply system and lighting
- Safety system: smoke and hydrogen detection unit, fire suppression system
- Cooling system: totally redundant, internal and external units

## What does it do?

The heart of the system, a TLE Series™ UPS, uses the unreliable and often low-quality power supplied by the grid or generator as “raw material”, to create a completely new, constant, moderated output with a fully regulated voltage and frequency.

When the grid or emergency generator is not able to supply the demanded power, the UPS seamlessly switches to an alternative source: energy stored in the battery bank. When the grid or generator output returns, the UPS continues to deliver its reliable high quality output, and simultaneously starts recharging the battery bank. Hardware and data are protected and operations are reliably maintained.





For fast deployment of highly-efficient, mission-critical power needs ideally suited for:

- Data centers, new and expansion
- Industrial plants
- Healthcare - digital imaging
- Airports
- Disaster recovery
- Traffic systems
- Communication nodes
- Temporary capacity during data center renovations, UPS upgrades, large events

## What does it look like?

Depending on the rating, the all-in-one PowerMOD system is housed in a single 10/20/40ft ISO High Cube container. Please refer to the specifications for details.

## Benefits

Deploying the GE PowerMOD brings a number of benefits compared to the traditional on-site “brick & mortar” solution:

- Flexible expansion—In case of increasing power demands, the power protection system can be easily expanded, either with separate compartments or with a cluster of containerized units
- Outsourced design—A single supplier for the complete integrated module simplifies project management
- Mobility—The plug-and-play modules are well suited for military and disaster recovery applications
- FAST FORWARD: Time & cost savings—In the modular construction process equipment is pre-installed off-site in factory, speeding up the time to value. The complete, fully integrated and pre-tested module can be provided in as little as 15 weeks, saving up to 30% compared to newly build

## Specifications

POWERMOD SYSTEM	CS200-10	CS200-20	CS400-20	CS800-40	CS1200-40
Rating (kW)	200	200	400	800	1200
Battery runtime at 100% load and 0.8 pf	5 minutes				
Battery type	VRLA on racks or in cabinets				
UPS data	TLE High Efficiency Transformerless, up to 99% off				
Input voltage and frequency	340 – 460VAC, 3-phase, 45 – 66 Hz				
UPS output power factor	1.0				
UPS output rating (kW)	200	200	400	800	1200
UPS output voltage	3x380/400/415VAC + N				
Container Data					
Container	ISO 10' High Cube	ISO 20' High Cube	ISO 20' High Cube	ISO 40' High Cube	ISO 40' High Cube
Dimensions (WxDxH, mm)	3050x2440x2890	6060x2440x2890	6060x2440x2890	12190x2440x2890	12190x2440x2890
Total container weight, kg	4800	6050	8440	14310	19250
Max floor load, kg/m <sup>2</sup>	2038				
Max speed wind exposure	150				
Protection degree	160 km/h				
Standards	IP54				
Other	EN1026 and EN12207 Class 4; EN12210 Class C4; EN12208 and EN1027 Class 5				

# Factory Services

## Project Management

Our project management solutions allow you to focus on business while we make sure your projects are delivered on-time and within budget. With our industry leading project management competencies and tenured experience, we deliver solutions through the complete technology lifecycle.

## Factory Acceptance Testing

Factory Testing can include, but is not limited to:

- Functional test on parallel RPA system including transfers to bypass, utility failure, EPO, etc.
- Full functional test on parallel RPA system including master fail and communications failure simulations
- Steady state measurements from 0-100% load of voltage, current, output voltage regulation, input/output power factor, output voltage THD, input current THD, frequency
- Overload of full system up to 150%
- 100% utility failure with waveform capture
- 0-100% step loads with waveform captures
- Output short circuit with waveform capture
- Removal of module from the system with waveform capture
- Inverter or power supply failure simulations
- Full functional test of RPA output switchgear including transfers in and out of main bypass mode
- eBoost functionality tests





# GE UPS Services

Your electrical infrastructure's availability, stability, and adaptability are crucial to your business success. Rely on the support professionals who know your systems best! GE's UPS Services offerings range far beyond standard product support: from on-site services for risk-reducing installation and startup, to availability services to help you proactively reduce downtime and meet your service-level commitments.

From installation to product retirement, warranty upgrades to remote monitoring, proactive care to 24/7 problem resolution, you can rely on GE's field service organization for all your electrical infrastructure support needs.

## Our Service Portfolio

GE services are designed to provide life long operation of all our UPS systems. We have a range of service offerings to meet your requirements. We are at home in all areas of industry and business life, specialized in solutions and services for your electrical infrastructure.

### On-Site & Emergency Services

- 24/7 Emergency hotline
- Installation
- Commissioning, start-up
- Repair, upgrade, retrofit
- Assessment, inspection, testing
- Online assistance
- Battery measurement / monitoring

### Contractual Services

- Maintenance service contracts
- Remote Monitoring & Diagnostics
- Preventive, planned maintenance
- Resident technical services
- Upgrade management
- Project & site management
- Consultancy and audits

### Parts and Repairs

- Spare parts supply
- Repair services
- Product replacement / return
- Equipment rentals
- Battery replacement

### Training

- Training for operators
- Training for maintenance staff
- Product training
- Trainer-to-student as well as web based training

## Maintenance Programs

The reliability and efficiency of your electrical infrastructure ultimately depends upon the maintenance programs you choose. The best power protection system in the world is only as good as its service and support systems.

A maintenance agreement is an opportunity for you to increase productivity and availability while lowering your owning and operating costs. Preventive maintenance helps you find equipment problems before they cause failure, leaving you with fewer repairs and less unscheduled downtime.

We have tailored our service contracts to meet your individual demand by offering three different contract types:

- BASIC Service—Annual maintenance, technical support 24/7 and defined intervention time
- VALUE Service—BASIC features plus free intervention in case of emergency
- PREMIUM Service—VALUE service features plus all material needed for repair

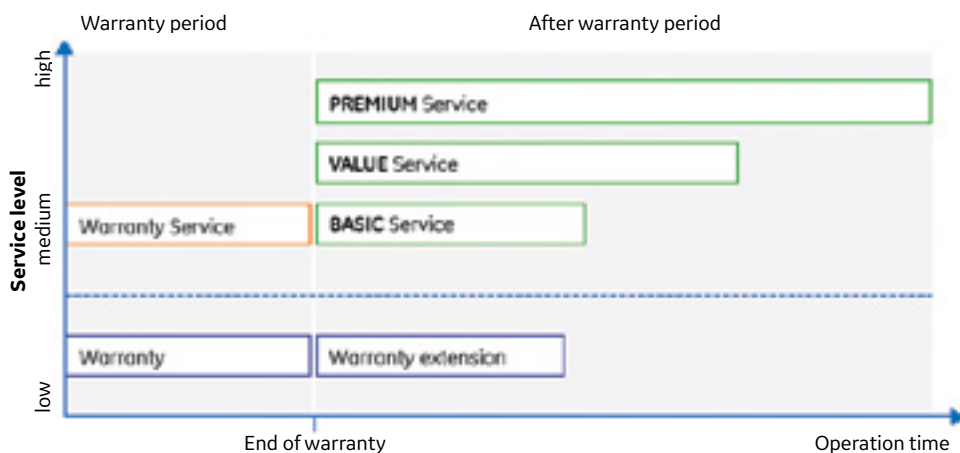

## Contract Features

Depending on your requirements, you can choose from following services:

- 24/7 technical support by our local Service Centre
- Guaranteed presence on site within the agreed time (Next Working Day, 12, 6 or 4 hours)
- Annual maintenance visit to analyze the UPS and operational conditions
- Spare parts included for emergency repairs
- Guaranteed 24/7 availability in our stock for most common parts for your UPS
- Preferential pricing for parts and hourly rates
- iUPSGuard Remote Monitoring & Diagnostics (RM&D) (optional, included in PREMIUM)

Service Contracts					
	WARRANTY	WARRANTY SERVICE	BASIC SERVICE	VALUE SERVICE	PREMIUM SERVICE
<b>Maintenance visit</b>					
Work/Labour	X	√	√	√	√
Travel	X	√	√	√	√
Software Upgrades	X	√	√	√	√
<b>Emergency repairs</b>					
Work / labour	√	√	X	√	√
Travel	√	√	X	√	√
Replacement parts*	√	√	X	X	√
Response time	X	√	√	√	√
<b>Technical support</b>					
Hot-line 24/7	X	√	√	√	√
Maintenance report	X	√	√	√	√
iUPSGuard remote monitoring	O	O	O	O	√

√: included

X: not included

O: optional

\* excludes batteries

# Target Vertical Markets

## Data Centers

Reliability, availability, electrical performance and cost are key features in the UPS market and in particular for Data Centers. GE's technology offers same/better performance and reliability for less total operational cost. The latter includes the cost of the equipment, the maintenance as well as the energy consumption. Therefore, energy efficiency is a fundamental aspect together with reliability and preventative maintenance.

Power transformers  
**WaveCast**



MV switchgear  
**SecoGear™ & SecoVac™**



LV switchgear  
**SEN Plus**



Selective MCCBs  
**Record Plus®**



**UPS**



**Automation & Supervision**



Every % of improvement in the operating efficiency generates an annual energy saving of 13'000\$ for every MW of installed UPS power (@0.15\$/kWh). Additional savings comes from the reduced cooling requirements. This is why GE tackles efficiency improvements in many different ways during the system design, from the component selection through the converter topologies and operating modes to the critical power architectures.

Improving reliability and availability in data center facilities is the problem that every data center operator must tackle. Every data center architect needs to carefully analyse many aspects, e.g. complexity management, number of UPS modules, UPS utilization rate, generators, paralleling switchgears, scalability, concurrent maintainability, single point of failures, fault tolerance, reliability, availability, installation cost, energy cost, maintenance cost. All these aspects can be mapped into performance, availability and CapEx/OpEx.

GE can design and deliver Data Center critical power systems in all the well known architectures, e.g. Parallel Redundant, Block Redundant, Shared Redundant and System plus System.

### Parallel Redundant - N+1 System

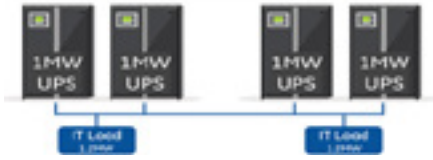

### Block Redundant - Catcher System

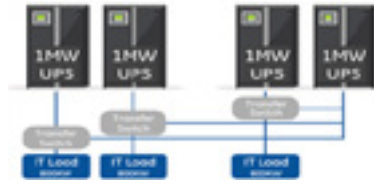

### Shared Redundant - 4N/3 System



### System + System - S+S

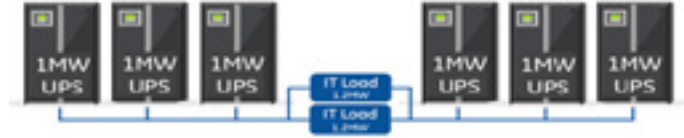

In addition, GE can provide its unique Ring Bus solution, an advanced power quality architecture to optimize performance, reliability and cost.

The GE Ring Bus architecture is a self-healing structure that offers

- Ultimate fault tolerance
- No single points of failure
- Lower number of UPS modules
- Higher UPS utilization rate and less stranded system capacity
- Simple and safe scalability
- Optimal utilization of breaker current capabilities
- Concurrent maintenance for critical path equipment
- No communication among UPS
- No limitations on the number of UPS and their distance
- Total system load shared across all UPS modules
- No need for synchronized inputs
- No needs for paralleling switchgears
- Potential fault current limitation

### IP Ring Bus

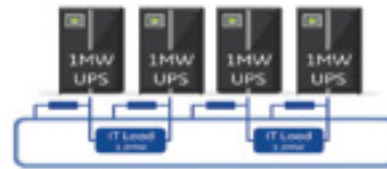

# GE Additive

Additive manufacturing technology is becoming more and more competitive if compared with traditional manufacturing technologies. 3D printers need to be protected from utility disturbances that may affect the quality of finished goods or even cause scrap of partially printed parts if the printing cycle operation is interrupted. Therefore, it is fundamental to address power quality requirements in additive manufacturing plants. GE has conducted systematic and comprehensive tests of several 3D printers and selected the optimal GE Uninterruptible Power Supply (UPS) products to be used in additive manufacturing applications to guarantee excellent power quality and reliability under all operating conditions.



## Building a global additive network

GE is investing in state-of-the-art facilities and leading talent focused on additive manufacturing technologies.

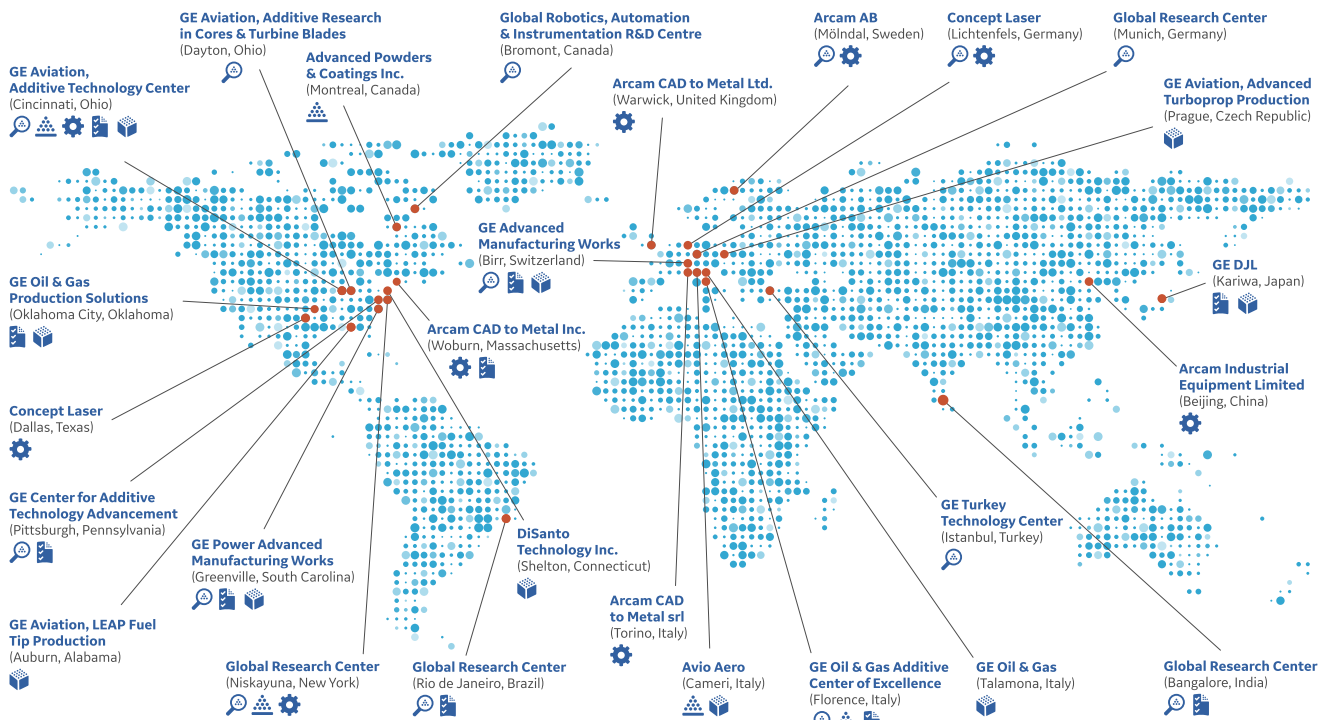

ADDITIVE RESEARCH & DEVELOPMENT	METAL POWDERS	ADDITIVE MACHINES, SUPPORT & SERVICE SOLUTIONS	ADDITIVE ENGINEERING SOLUTIONS	ADDITIVE PRODUCTION
---------------------------------	---------------	--	--------------------------------	---------------------



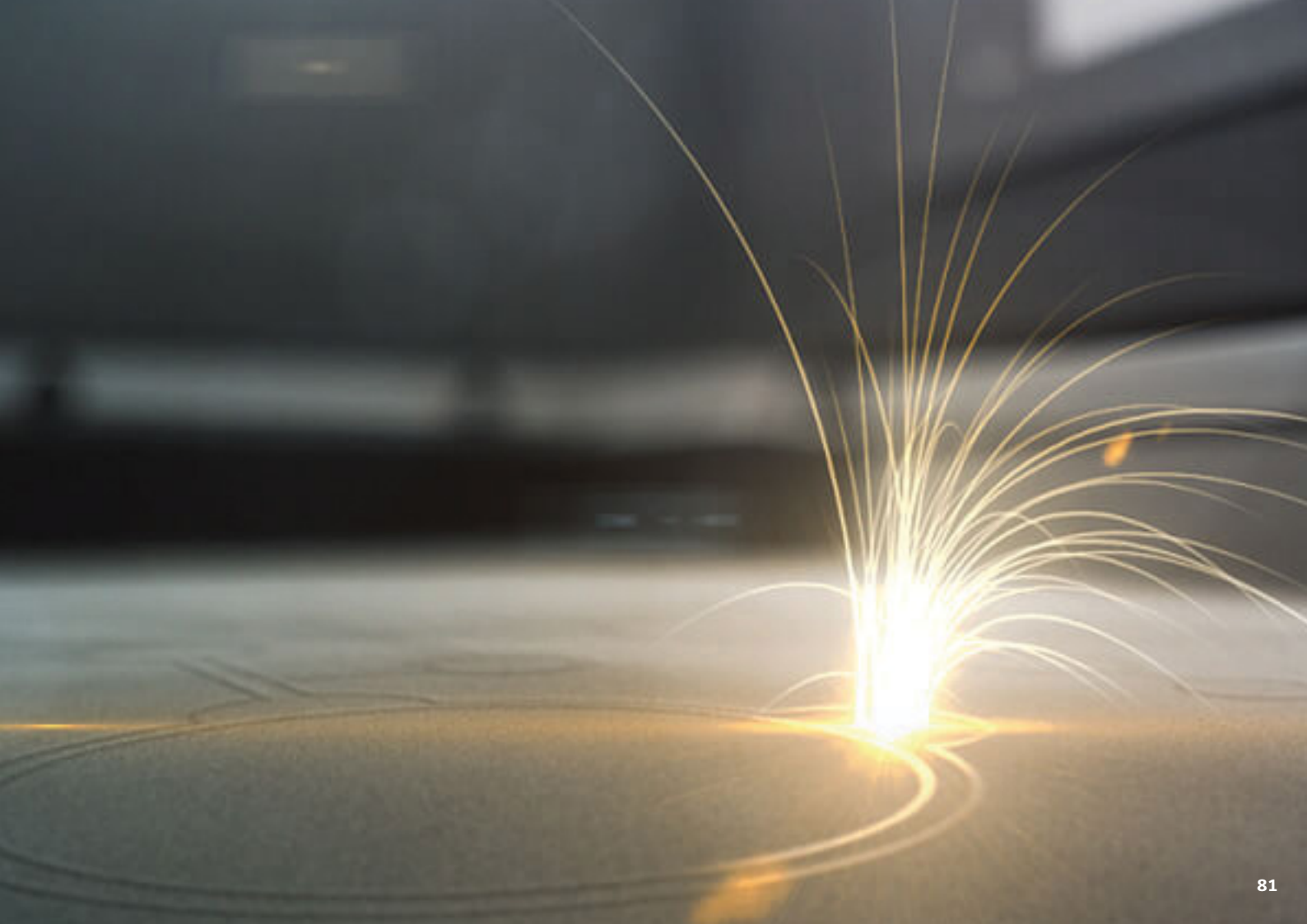

# Rail

## Portuguese Railway

### Challenge

- The railway company used their own power source, through the catenary, for the trains and, simultaneously, for the signaling system;
- However, this method creates many variations, caused by several trains at the same time, the type of train and the fact they are braking or accelerating;
- These issues most of the time resulted in the failure of the signaling, this way preventing the trains to circulate

### Application for Single-Phase Systems

- Cabinet Mount for indoor or outdoor UPS
- GE UPS LP11
- Isolation transformers
- High capacity battery string, and additional Battery Charger
- ATS System
- Electronic Stabilizer
- Frames power systems (Stabilizer; ATS, UPS Auxiliary Charger)
- Switchboard (power loads)
- Infrastructure

### Application in Three-Phase Systems

- GE UPS SitePro 10, 20 & 30 kVA
- Isolation transformers
- Battery Strings with large capacity
- Rack with rectifiers
- Frames power systems (UPS and Rectifiers)
- Switchboard (power loads)
- Infrastructure

## North Corridor Mozambique Railway

### Challenge

- One of the biggest projects running in Africa on the mining field (Coal)
- A Railway line of 900 Km
- Goes from Tete until the Nacala Harbor, crossing Malawi
- The goal is to run, by day, 24 trains (today only one)
- For that, a new fully equipped infrastructure is on the way;
- LCPower will provide, to all the 67 sites along the line, the Power equipment and Energy infrastructure

### On-site

- GE UPS SG 10, 15, 20 or 40 kVA
- Battery String with 4 hours autonomy
- GenSet 10, 22 or 33 kVA, for continuous service
- System automatic fuel supply from an external reservoir of 2000 liters
- Infrastructure mechanics associated with the GenSet
- Electrical Inverter Network / Group Board for normal and emergency distribution



H.J.M. CRANES  
011 429 7549  
BRANDERBURG, SA  
PO BOX 100, SA  
06101, SA

# Healthcare

## Consistent Imaging Quality

- Performance and uptime of imaging equipment
- Reduce the need to reschedule patients due to equipment downtime
- Prevent the loss of scan and imaging data

## UPS Protected

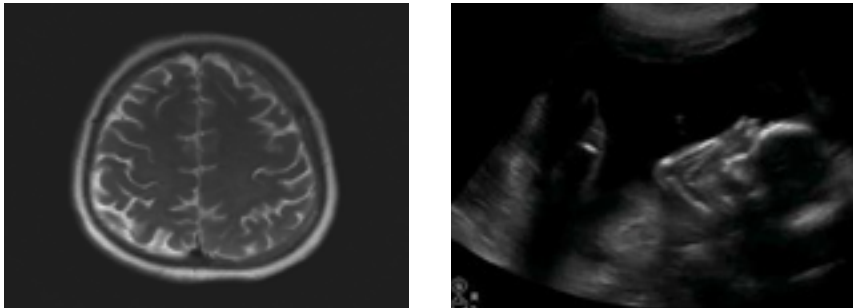

## Superior Battery Management

Every GE UPS incorporates a standard feature called Superior Battery Management (SBM) that can be configured to periodically test the battery system and calculate true battery runtime using measured values for temperature and load.

- Quick Battery Test
- Deep Battery Calibration
- Accurate Runtime Prediction
- Automatic boost / float charger
- Temperature compensated battery charging
- Load dependent end of discharge voltage
- No load shutdown

## Strong Overload Capability

Great overload capability, ensuring power protection safety for applications requiring start-up overcurrent and for temporary peak load.

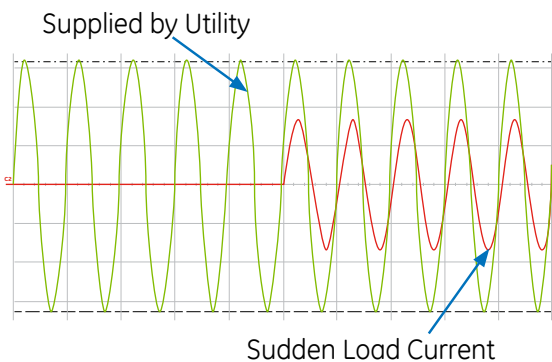

## Solid Supply Independently from Load Stressing

Picture shows that when the medical modality begins to work (red sinusoid starts) the waveform is always very clean and sharp both at the input of the UPS (green) or at the input of the modality (red).

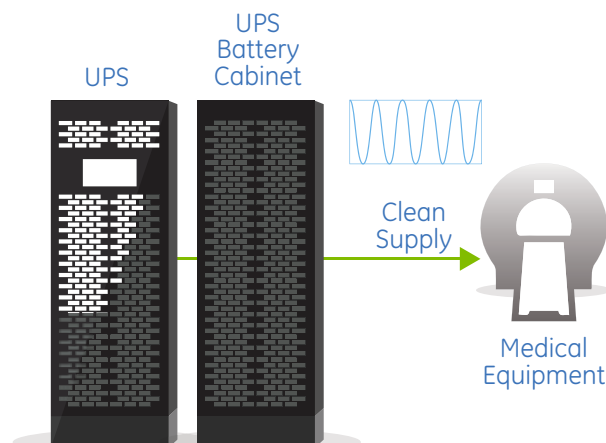



# Maritime

## Power quality solutions for a technology-dependent maritime world

The maritime industry is growing. The fast technical development has increased the usage of electronic equipment onboard. The ship building industry offers a variety of different products: oil/gas tankers, cruise ships and yachts, ferries and fishing fleets, offshore and maritime defense equipment.

Expensive maritime equipment must be used efficiently. Even a short system crash can lead to substantial costs and cause lengthy organizational problems. Additional consequences include loss of engine control or communication and navigation systems potentially leading to severely dangerous situations.

Most technical outages in the maritime environment are caused by insufficient quality in the power supply mainly because of old generators. As well as the directly visible impacts above, a poor utility power supply causes premature aging of electronic devices leading to higher maintenance costs.

Now more than ever before, safe and managed electric power is needed for a wide range of maritime applications, including...

- Ship operation equipment
- Navigation equipment
- Telecommunication
- Safety facilities
- Cargo handling systems
- Computer networks
- Entertainment facilities
- Electronic point of sale equipment
- Security systems
- Emergency systems
- Specialized machinery

For all possible situations arising on board of a modern vessel, the uninterrupted availability of high quality electricity has become vital for a safe and profitable journey.

Today GE is the only manufacturer in the market supplying a full range DNV certified UPS product line: the VH Series UPS.

### Full Range DNV Certified:

#### 700-3000 VA

As one of only a few suppliers worldwide GE has a type approval certificate from the Det Norske Veritas (DNV) certification body for one of its UPS models. The certified VH Series was not specifically redesigned for the maritime environment; the full range of standard UPSs passed the severe tests equipped with a maritime mounting kit! On top of that GE's VH Series 2kVA 208/220/230/240V model is IACS, CE and UL approved.

The certification proves the VH's high quality and its suitability for the rough environmental and EMC conditions onboard. This simplifies installation and documentation requirements significantly.



The DNV certification also stands for the following agencies (as per the International Association of Classification Societies - IACS - standards:

- American Bureau of Shipping (ABS)
- Bureau Veritas (BV - Holland)
- China Classification Society (CCS - China)
- Det Norske Veritas (DNV - Norway)
- Germanischer Lloyd (GL - Germany)
- Korean Registrar of Shipping (KRS - Korea)
- Lloyd's Register (LR - UK)
- Nippon Kaiji Kyokai (NKK - Japan)
- Registro Italiano Navale (RINA - Italy)
- Russian Maritime Register of Shipping (RMSR - Russia)
- Indian Registrar of Shipping (ISR - India)



## Secure Your Bridge Applications and IT - VH Series UPS 700-3000 VA

Bridge applications, local PCs and communication systems as well as fishery products – all these mission critical applications can be protected with a UPS from the VH Series range. This plug-in-UPS helps you to protect your equipment cost efficiently.

VH Series UPS have - like all other GE UPS - comprehensive monitoring tools, which provide efficient event management and maintenance even in a decentralized structure with a multitude of equipment.

## Features and Benefits

- VFI (Voltage and Frequency Independent) technology eliminates power reliability problems
- Unique failsafe internal bypass for continued operation even in the event of UPS failure
- Tower and/or 2U rack design for all ratings; all support elements included
- Simple battery replacement without disruption to supported load
- Versatile communication with USB and contact interface, RS232, relays and SNMP
- Wide input voltage window minimizing battery usage
- Excellent short circuit protection
- GE's unique Superior Battery Management enhancing battery performance and lifetime
- Easy plug-in connection of battery packs for extended run-time
- Remote monitoring and control for unmanned or isolated sites
- Can be used as a 50/60Hz frequency converter
- Phase neutral reversal protection
- High overload capability
- Precise output frequency regulation
- High efficiency
- Optional maritime kit to further strengthen the UPS in harsh maritime environments with high vibrations and poor mains quality

## Maximize The Efficiency of Your Communication and Navigation Systems - LP Series UPS 3-30 kVA

GE's LP Series of single and 3-phase UPS is the ideal UPS support for communication and navigation instruments. In the United States the LP11 Series is classified with the designation LPS Cat III (Instrument Grade Laboratory Protection System), meaning it is designed to efficiently protect critical equipment and processes.

Excellent quality of supply voltage, galvanic separation and flexible autonomy times are key characteristics to successfully support communication and navigation systems. Furthermore LP11 UPS are successfully used to protect maritime training systems and process automation.



## Features and Benefits - Maritime

- VFI (Voltage and Frequency Independent) technology eliminates power reliability problems
- Low input current distortion and high input power factor eliminates the need for costly filters or oversized generator
- Small footprint
- Advanced technology enabling silent operation
- High output power factor allows for optimal sizing of UPS
- Low output voltage distortion
- Superior Battery Management (SBM) to enhance battery life and to prevent battery failure
- ECO mode enables automatic energy savings under stable power conditions

## The Ideal UPS For Your Centralized Solutions - SG Series UPS 10-500 kVA

Steering systems, engine and gear-systems control, cranes.... all complex and mission critical systems. Due to its specific requirement related to power supply, such equipment has high demand for a clean and safely managed supply of input power.

GE's SG range of UPS was successfully tested for use with maritime electronic equipment. GE's exclusive power control system means smaller rated UPS systems can be used, still ensuring a perfect waveform to the load even on peak loads. Thus GE helps you provide excellent customer service and process management by ensuring business continuation, resulting in improved business efficiency.

## Features and Benefits

- VFI (Voltage and Frequency Independent) technology eliminates power reliability problems
- High output power factor eliminates need for UPS oversizing
- Constant high efficiency at full and partial load
- Superior Battery Management (SBM)
- ECO mode/eBoost™ for energy savings
- Extremely low output distortion even at non-linear loads
- Highest levels of reliability and flexibility with Redundant Parallel Architecture (RPA)
- Best in class for variable load applications
- Various operation modes: double conversion; voltage and frequency stabilizer; frequency converter
- Galvanic isolation which provides additional critical power protection
- Backfeed protection standard included providing a safe work environment







# Misc Application & Technical Notes

## IS Power Distribution System

In electricity supply systems, an earthing system defines the electrical potential of the conductors relative to that of the Earth's conductive surface. The choice of earthing system has implications for the safety and electromagnetic compatibility of the power supply. Note that regulations for earth (grounding) systems vary considerably between different countries.

A protective earth (PE) connection ensures that all exposed conductive surfaces are at the same electrical potential as the surface of the Earth, to avoid the risk of electrical shock if a person touches a device in which an insulation fault has occurred. It also ensures that in the case of an insulation fault, a high fault current flows, which will trigger an over current protection device (fuse, MCB) that disconnects the power supply.

International standards require that electrical installations implement two types of protection of person against the dangers of electrical currents.

- Protection against direct contact with conductive parts that are intentionally live. This protection is provided by barriers or enclosures for which the design and type define the corresponding IP degree protection index.
- Protection against indirect contact with conductive parts that are not normally live but which may become live accidentally. This protection is provided by disconnecting the supply of power when the potential difference of these parts becomes dangerous. International standard IEC 60364 distinguishes three families of earth arrangements using the two-letter codes TN, TT, and IT (three letter codes only for TN systems)

International standard IEC 60364 distinguishes three families of earth arrangements using the two-letter codes **TN**, **TT**, and **IT** (three letter codes only for TN systems)

FIRST LETTER	SECOND LETTER	THIRD LETTER (ONLY FOR TN SYSTEMS)
Connection of the Neutral	Earthing of the equipment	Protection conductor
T - Direct connecting to the earth of the power distribution	T - Connected to a local earth independent from the power distribution earth	C - Neutral and protective conductor (PEN) are combined in a single conductor
I - Isolated from the earth	N - Connected to the earth of the power distribution	S - Neutral and protective conductor (PE) are distributed separately

TT SYSTEM	PHOTOS
<p>The power distribution system have one point directly earthed:</p> <ul style="list-style-type: none"> <li>- the neutral is connected directly to earth</li> <li>- the masses are earthed independently of power earthing</li> </ul>	

IT SYSTEM	PHOTOS
<p>The power distribution system is isolated from the earth, except that one point may be connected to earth through an impedance or a voltage limiter:</p> <ul style="list-style-type: none"> <li>- the neutral is isolated or connected to earth by an impedance</li> <li>- the masses are earthed independently of power earthing</li> </ul>	

**TN-S**

The power distribution system is directly earthed:  
- the neutral is connected directly to earth  
- the masses are connected to the same earthing point of neutral

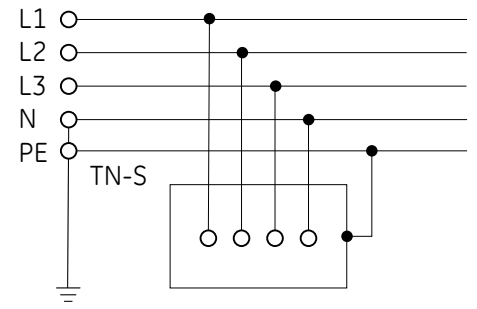
**PHOTOS****TN-C**

Neutral and protective conductor (PEN) are combined in a single conductor.

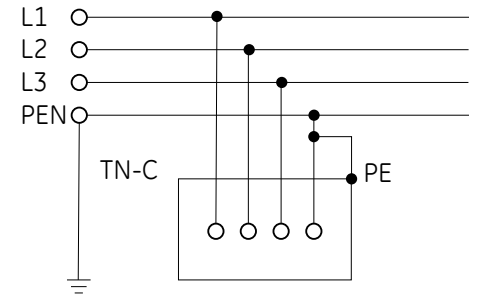
**PHOTOS**

NOTE: The UPS is designed for TN System. The input neutral shall be grounded at source and shall never be disconnected.



# Transformers

## Input Isolation Transformer

Typically a UPS system is directly connected to the Input Mains. In some applications a galvanic separation between the UPS and the Input Mains or a dedicated grounding system for the UPS and its loads is required. In these cases an input isolation transformer on the UPS rectifier or bypass Input Mains shall be installed.

## Transformer Types

Three different transformers types, characterized by wiring connections, can realize the UPS galvanic separation. The tables here below show the different characteristics of the type used and the relative applications:

## Transformers Typology

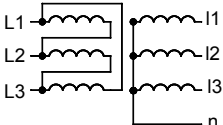
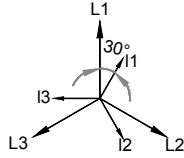
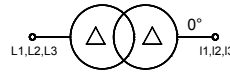
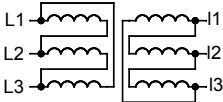
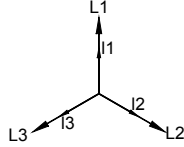
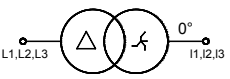
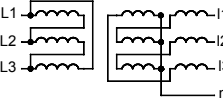
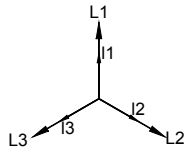
MODALITY	EQUIPMENT	PRODUCT	POWER	BATTERY RUNTIME (FULL LOAD)
Dyn11				30 electrical degrees phase shift between primary and secondary wiring neutral on secondary wiring
Dd0				0 electrical degrees phase shift between primary and secondary wiring
Dzn0				0 electrical degrees phase shift between primary and secondary wiring neutral on secondary wiring

# Transformers Typology Applications

TYPE	BYPASS INPUT ISOLATION TRANSFORMER	RECTIFIER INPUT ISOLATION TRANSFORMER
Dyn11	X	X
Dd0	-	X
Dzn0	X	X

## Input Rectifier Isolation Transformer

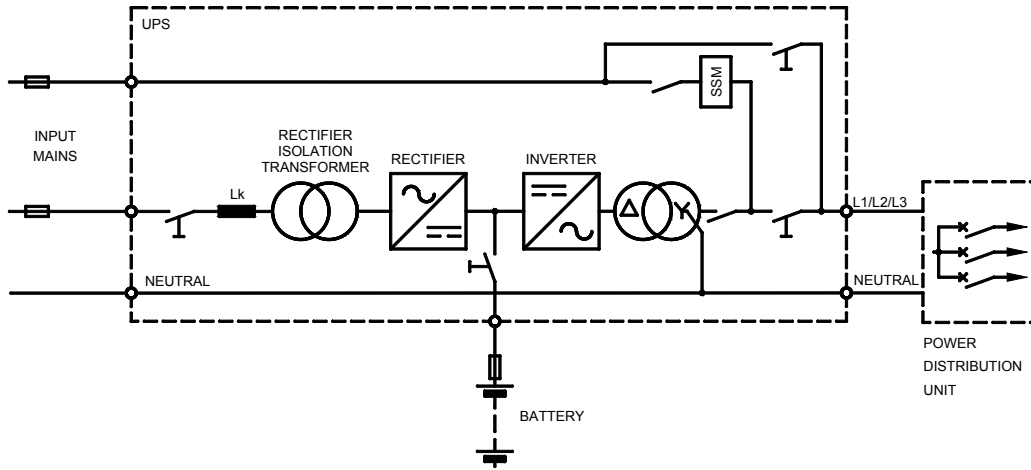

### Configuration

The isolation transformer is installed upstream the UPS rectifier between the rectifier and the Input Mains; the transformer neutral shall be not ground (earth) connected.

### Applications

For safety reason, to realize a galvanic separation between the Input Mains and the UPS rectifier. This configuration is typically used with PB battery (not VRLA) that require periodical check by service engineers that operate directly on the battery (e.g. filling in electrolyte in battery blocks or checking the electrolyte density).

### Efficiency Effect

The total UPS efficiency is affected by the transformer of about 1-2% .

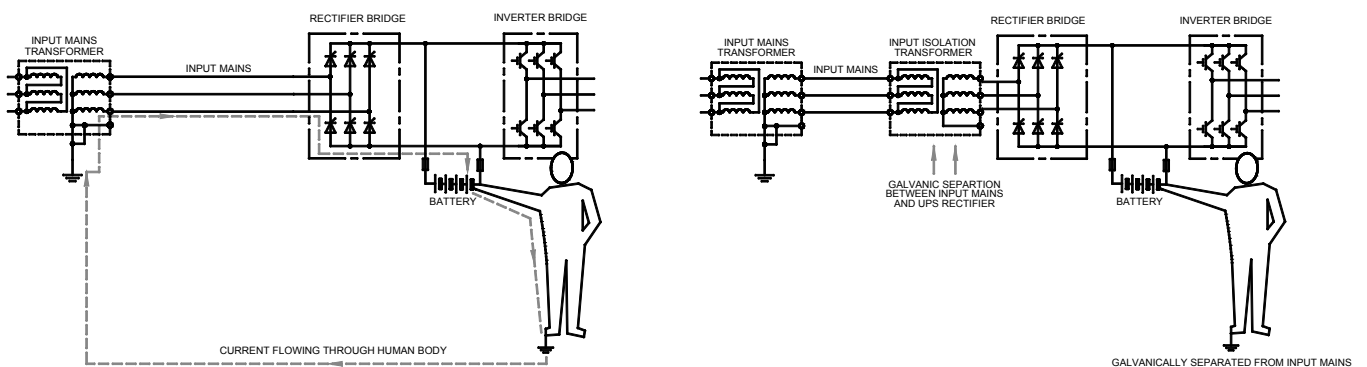

## Input Bypass Isolation Transformer

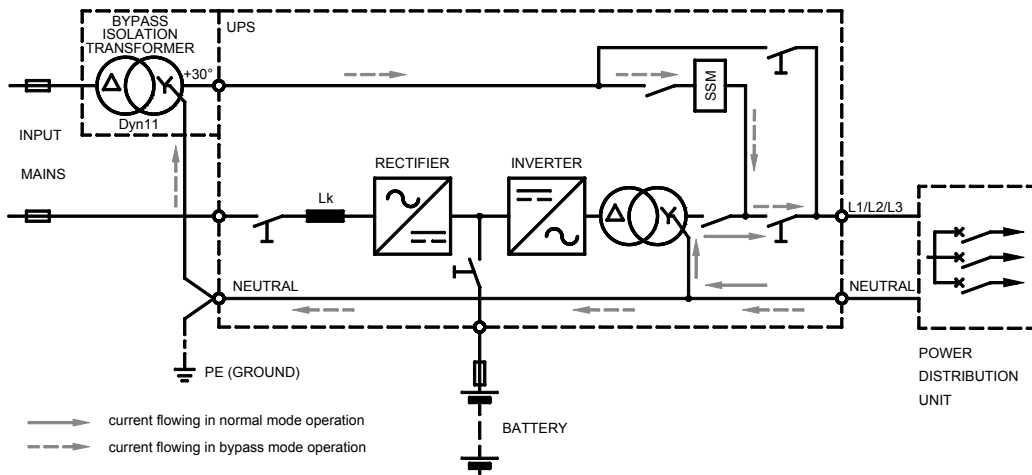

## Configuration

Configuration realized by a transformer installed on the UPS bypass input. Two different transformers can be used:

- Dyn11 (30 el. degr. phase shift) for the applications where the transformer phase-shift has no influence on the UPS output. Standard configuration.
- Dzn0 (0 el. degr. phase shift) where an UPS input/output electrical phase shift is not allowed. Solution more expensive than the previous one, due to the zig-zag transformer winding. This configuration is used when an external maintenance bypass is installed, to avoid phase shift with the UPS bypass.

## Applications

- To realize a local grounding arrangement or to realize the neutral wiring for the UPS and its loads, different from the one available on the Input Mains. This is the case where the UPS Input Mains is distributed without neutral (3 wire + ground) or where the replacement of the existing neutral conductor with a larger one could be problematic or costly.
- To avoid the propagation of the UPS loads current upstream the UPS on the Input Mains, even when the UPS is running in *bypass* mode.

In fact with the UPS in normal mode, with the loads supplied by the UPS inverter, the current is limited to the inverter transformer without any propagation on the Input Mains distribution (refer also to the fig. 4-1). When the UPS is running in bypass mode the load current is spread on the UPS input electrical distribution; this can cause problems on other load there installed specially when the UPS supply non-linear loads with high harmonic contents or with high unbalanced loads (with high 3rd and multiple harmonic contents specially on the neutral conductor).

## Efficiency Effect

The introduction of a transformer on the bypass line has no influence on the UPS efficiency because not part of the UPS normal mode power conversion operation.

## Input Bypass Transformer with External Maintenance Bypass

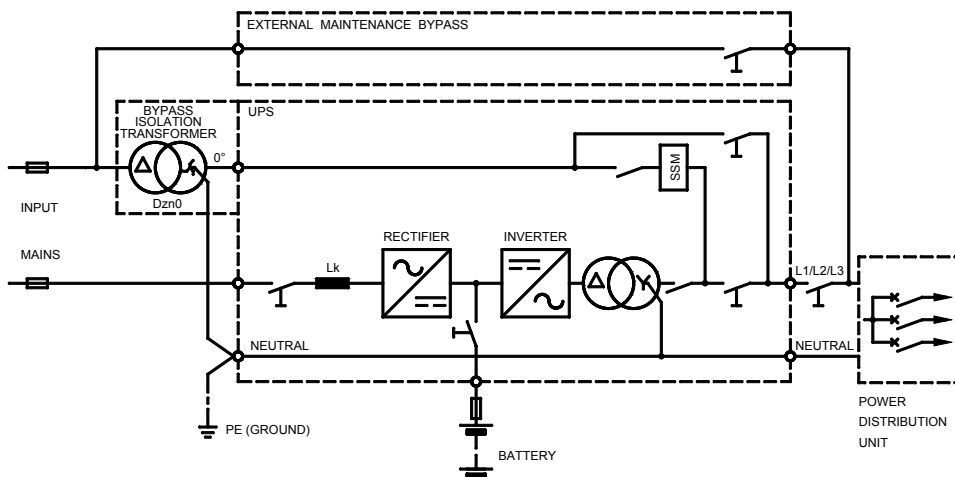

In some UPS applications an external maintenance bypass for UPS and bypass transformer is required for maintenance reason or to allow the possibility to remove the UPS maintaining the loads active. With this configuration it must be taken into account to have no phase shift between the UPS and the external maintenance bypass circuits.

If a bypass isolation transformer is required, it shall be realized by a Dzn0 (Delta zig-zag with 0 el. degr. phase shift).

Careful attention shall be taken if a differential protection relay is installed upstream in the UPS. This can have a false trip if the grounding connection between the “Input Mains transformer” and the “Input isolation transformer” is not realized properly.

### Autotransformer

Adding an autotransformer is possible to adapt the input and (or) the output UPS voltage. The use of this one at the ups input is allow only if the neutral is available. Contrarily a Dyn transformer is mandatory. An Autotransformer is an electrical transformer with only one winding, thus there will be no galvanic separation. Because it requires both fewer windings and a smaller core, an autotransformer for power applications is typically lighter and less costly than a two winding transformer.

### Bi-Mono Transformer

By using a bi/mono transformer is possible to supply a mono-phase load. The size of UPS will be 1,78 times the load applied. In fact:

$$VA_{load\ mono} / 0,97\ (trasf.) / 400V = I_{phase-UPS}$$

$$I_{phase-UPS} \times 3 \times 230V = P_{min-UPS}$$

Anyway bypass is always available and only two-phases will be loaded.

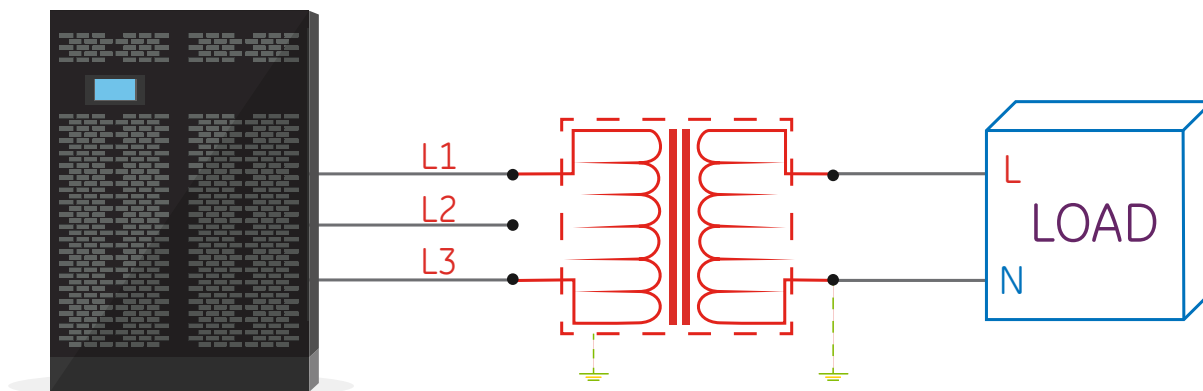

# Circuit Breakers & Selectivity

## SELECTIVITY COORDINATION

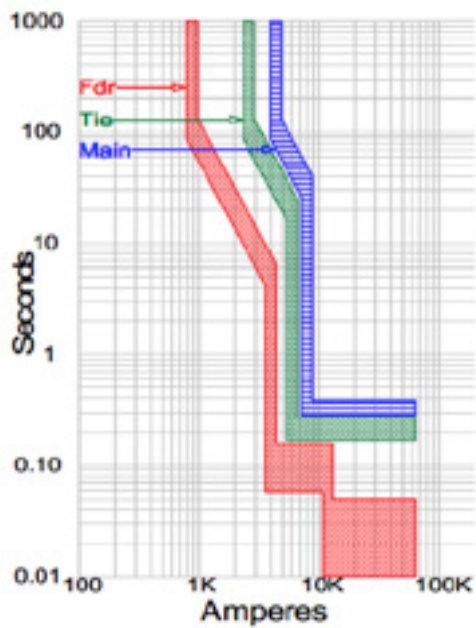

Proper circuit selectivity has to guarantee MCCB's working condition as the one described in the picture aside.

In an electrical system, upstream MCCB (Main, in blue) has to withstand higher current for longer period compared to downstream connected MCCB.

Therefore current ratings and time delays has to be made according to this criteria.



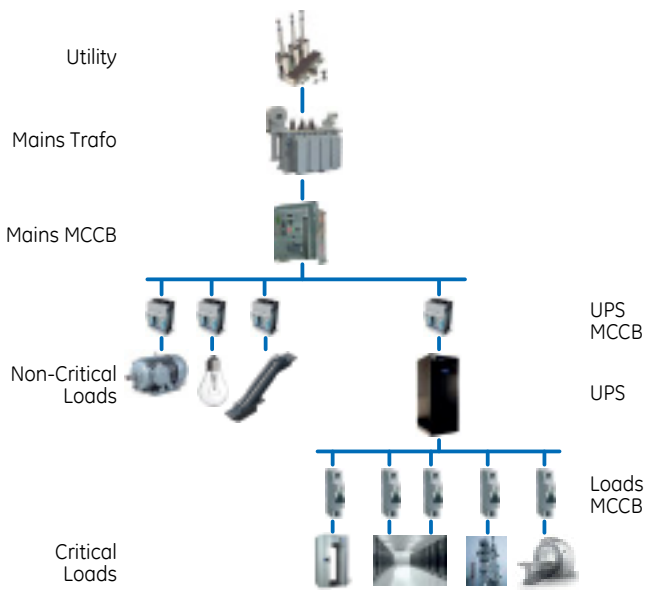

Steady state scenario

UPS is installed between Low voltage Mains and Critical Loads. Upstream and downstream protection devices are needed to guarantee Selectivity criteria in case of any fault

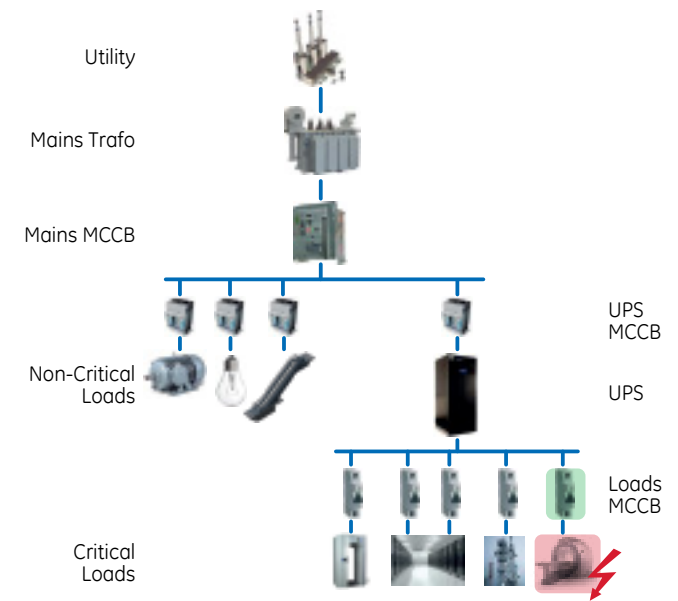
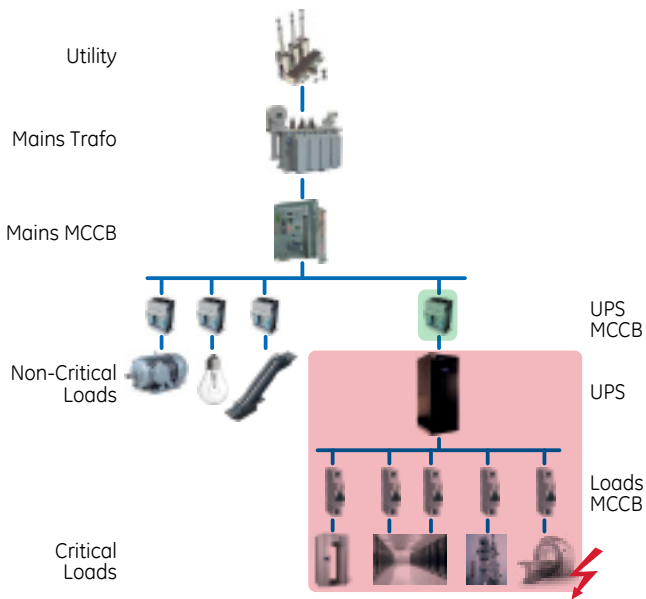

Let's consider a fault scenario

A short circuit occurred on one of the load branches supplied by the UPS.

Protection devices selectivity has been properly sized: Due to trip of its upstream breaker, shorted load is disconnected without affecting other load branches, keeping rest of installation safe and active.

Same scenario: short circuit in one load branch

Protection devices selectivity has been wrongly sized: Its upstream breaker doesn't trip, UPS switches on bypass and short circuit current flows through making UPS MCCB trip.

The whole downstream circuit is disconnected. This obviously means damage for customer.

# Battery Technologies

## Battery Charging Characteristics

To choose and properly size a battery capacity and a battery charger, some basic information are necessary.

### Capacity [Ah]

First of all, to compare different battery brands, the main important thing is to compare the same Capacity [Ah] value; the Ah capacity is the current a battery can provide over a specified period, for example a 100Ah C10 end of discharge 1.75V/cell, can provide 10 A for 10 hours to an end discharge voltage of 1.75V per cell.

Different battery manufacturers will use different CXX rates depending on the market or application at which their batteries are targeted. Typical rates used are C3, C5, C8, C10 and C20.

In the following example both manufacturers can offer a 100Ah battery but, Manufacturer A can supply the 100Ah at C3 (and 135Ah at C10) and Manufacturer B can supply the 100Ah only at C10; in this case the Manufacturer A battery is better than the one offered by Manufacturer B.

		STANDBY TIME (HRS)							
		1	2	3	5	8	10	12	20
Manufacturer 'A'	Current	80.9	47.4	<b>35.0</b>	23.2	16.2	13.57	11.4	5.9
	AH (Cxx rate)	80.9	94.8	<b>105.0</b>	116.0	129.6	135.7	136.8	138
Manufacturer 'B'	Current	66.9	38.5	27.7	18.2	12.3	<b>10.2</b>	8.6	5.77
	AH (Cxx rate)	66.9	77.0	83.1	91.0	98.4	<b>102.0</b>	103.2	115.4

### Battery charging current

For standard UPS standby applications the batteries are charged at floating voltage and the required charging time depends by the type of installation (number of charging/discharging phases, runtime, etc).

Usually, VRLA batteries charging current is limited to 0.3 C10, and 0.1 C10 is the normal recommended charging current during normal UPS operation.

Charging current value is strictly connected to the required recharging time, for example to charge a battery from up to 80% the following charging times are needed:

- 4 hours with 0.2 C10
- 8 hours with 0.1 C10
- 16 hours with 0.05 C10

(Typical example of the charge characteristics for the standby use)

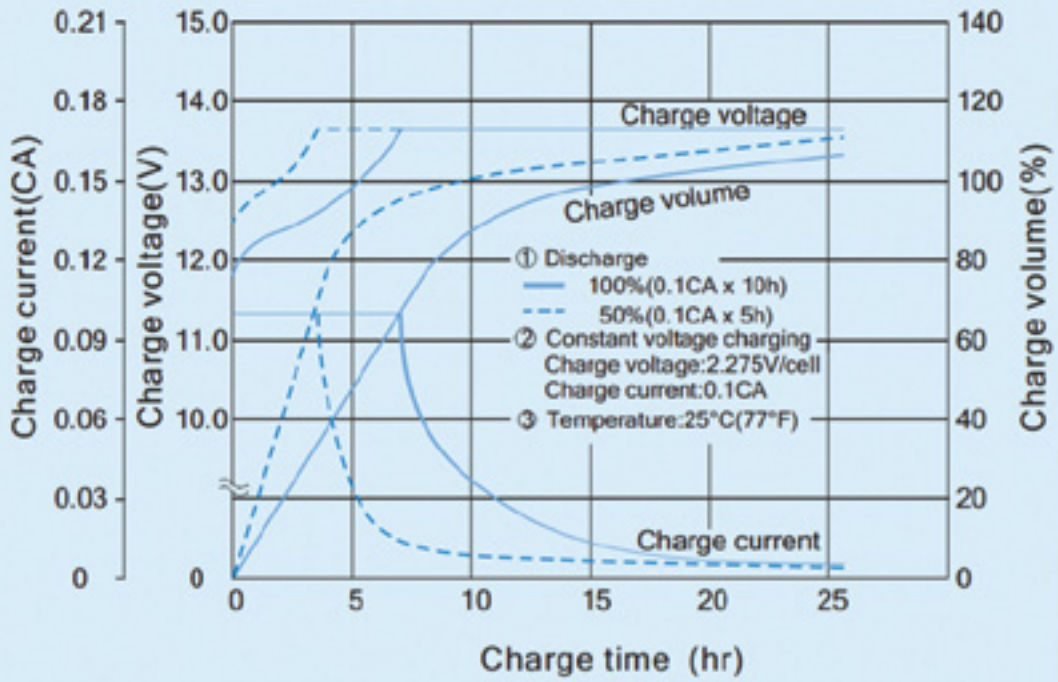

Average Battery Discharge Characteristics

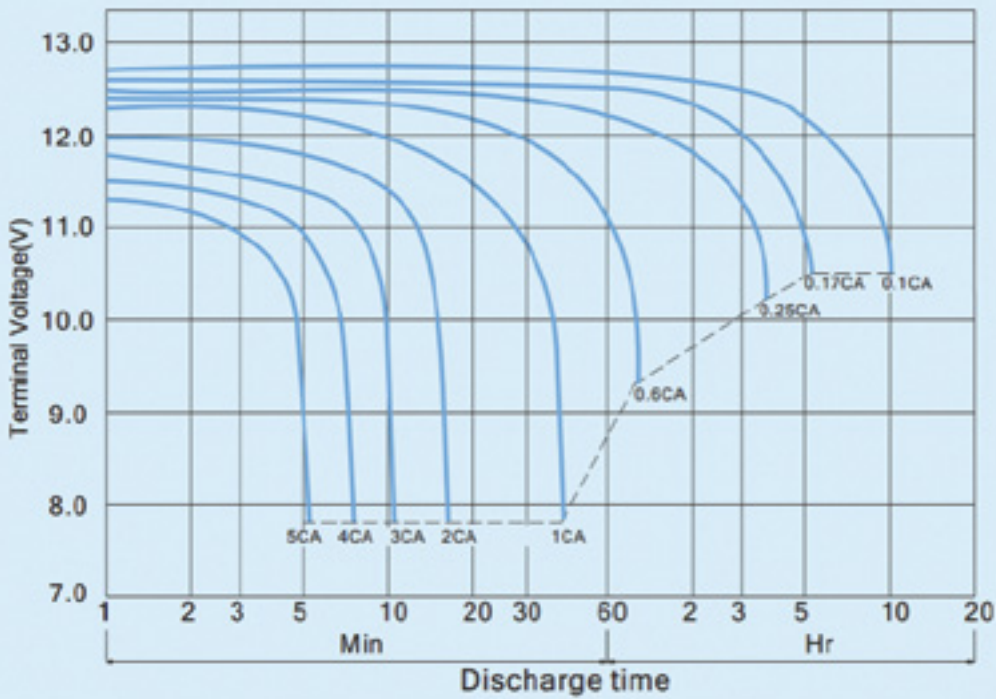

# GE Energy Connections

GE Energy Connections designs and deploys industry-leading technologies that turn the world on. We transport, convert, automate and optimize energy to ensure we provide safe, efficient and reliable electrical power. Uniting all the resources and scale of the world's first digital industrial company, we connect brilliant machines, grids, and systems to power utility, oil & gas, marine, mining and renewables customers, that keep our world running.



## Austria

General Electric Austria GmbH  
Technologiestraße 10  
Euro Plaza, Gebäude E, 5. Stock  
A-1120 Wien  
Tel. +43 (0) 1 260 16 251

## Belgium

GE Industrial Belgium  
Nieuwevaart 51  
B-9000 Gent  
Tel. +32 (0)9 265 21 11

## Finland

GE Industrial Solutions  
Kuortaneenkatu 2  
FI-00510 Helsinki  
Tel. +358 (0)10 394 3760

## France

GE Industrial Solutions  
Paris Nord 2  
13, rue de la Perdrix  
F-95958 Roissy CDG Cédex  
Tel. +33 (0)800 912 816

## Germany

GE Consumer & Industrial GmbH  
Robert-Bosch Str. 3  
D-50354 Hürth-Effern  
Tel. +49 (0) 2233/ 9719-0

GE IMV Deutschland GmbH  
Berliner Platz 2-6  
D-24534 Neumünster  
Tel. +49 (0) 4321 - 201 700

## Hungary

GE Hungary Kft.  
Vaci ut 81-83.  
H-1139 Budapest  
Tel. +36 (0)1 447 6050

## Italy

GE Industrial Solutions  
Centro Direzionale Colleoni  
Via Paracelso 16  
Palazzo Andromeda B1  
I-20864 Agrate Brianza (MB)  
Tel. +39 (0)39 637 371

## Netherlands

GE Industrial Solutions  
Parallelweg 10  
NL-7482 CA Haaksbergen  
Tel. +31 (0)53 573 03 03

GE IMV Nederland BV  
De Wel 18  
NL-3871 MV Hoevelaken  
Tel. +31 (0)33 254 12 80

## Poland

GE Power Controls  
Ul. Odrowaza 15  
PL-03-310 Warszawa  
Tel. +48 (0)22 519 76 00

Ul. Leszczyńska 6  
PL-43-300 Bielsko-Biała  
Tel. +48 (0)33 828 62 33

GE Industrial Solutions  
Budynek BPH, 1 piętro  
Ul. Towarowa 25a  
PL-00-869 Warszawa  
Tel. +48 (0)22 520 53 53

## Russia

GE Industrial Solutions  
27/8, Electroavodskaya street  
Moscow, 107023  
Tel. +7 (0)495 937 11 11  
E-mail: info-ups.ru@ge.com

## South Africa

GE Industrial Solutions  
Unit 4, 130 Gazelle Avenue  
Corporate Park Midrand 1685  
P.O. Box 76672 Wendywood 2144  
Tel. +27 (0)11 238 3000

## Spain

GE POWER CONTROLS IBÉRICA, S.L.  
Calle Miño 122 Naves E-F  
Polígono Industrial Santa Margarita  
S-08223 Terrassa (Barcelona)  
Tel. +34 (0)900 993 625

Calle Gobelás 35-37  
S-28023 Madrid  
Tel. +34 (0)91 7336000

## Switzerland

GE Consumer & Industrial SA  
Via Cantonale 50  
6595 Riazzino (Locarno)  
Switzerland  
Tel. +41 (0) 91 850 51 51  
email: info.criticalpower@ge.com  
www.gecriticalpower.com

## Ukraine

GE Ukraine  
42/44 Shovkovychna str.  
Horizon Tower, 8th Floor  
01601, Kyiv  
Tel. +380 (0)44 490 69 84  
E-mail: info-ups.ua@ge.com

## United Arab Emirates

GE Industrial Solutions  
Injaz Building, 3rd Floor  
Dubai Internet City  
PO Box 11549, Dubai  
Tel. +971 (0)4 4546912

## United Kingdom

GE Industrial Solutions  
2 The Arena, Downshire Way  
Bracknell, Berkshire  
RG12 1PU  
Tel. +44 (0)800 587 1239

3 Oakland Road  
Leicester, LE2 6AN  
Tel. +44 (0) 116 274 6205  
Fax +44 (0) 116 274 6201  
E-mail: sales-ups.uk@ge.com

